

Lab
5

Forces – Part 1

Introduction This is the first week of a two part lab that deals with forces and related concepts. A *force* is a push or a pull on an object that can be caused by a variety of reasons. There are many different types of forces that you will be dealing with in lecture but, for this lab, you are only going to concern yourself with two. The first, *weight*, is a force caused by the gravitational pull of a planet. The second is *tension* which is a force caused by a rope or string.

You will be using Newton’s 2nd Law to help you examine the nature of these forces. The 2nd law is ...

$$\Sigma F = ma$$

- | ΣF is the net force (in Newtons, N)
- | m is the mass (in kilograms, kg)
- | a is the acceleration (in meters/second squared, m/s²)

There are two different states that you will be dealing with when you use this law. One is *equilibrium* and the other is *non-equilibrium*. This week you will examine the equilibrium case.

The Equipment You will be using two different pieces of equipment today. One is called a *force probe*. This probe is attached to the computer and it will measure the force of a push or a pull on it. There should be a round platform attached to it. See **Figure 1**. The other piece of equipment will be described later.

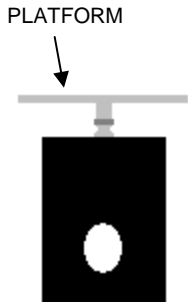

FIGURE 1 – Force Probe

Part 1 – Weight First you will examine the relationship between weight and mass.

A) Make a chart in your lab report like **Chart 1**.

Reading 1	Reading 2	W _{calc.}	%

CHART 1

- B) Open the file **FORCE PROBE**.
- C) Make sure the switch on the force probe is switched to ±10 N. Rest the probe on the table with the platform facing up.
- D) Push the ZERO button on the computer (next to the green COLLECT button).
- E) Place the black metal bar on the platform and take a reading. NOTE: If you have a negative reading, then ignore the negative sign. Place this value in the chart under **Reading 1**. Write down your units as well. The “N” stands for Newtons.

- F)** Take the black bar to the back of the lab room where you will find pan balances. Put the black bar on a left side pan.
- G)** Stack the round, slotted discs on the right pan until the system is balanced.
- H)** Add up the values labeled on the discs and put this value in the chart under **Reading 2**. Note the units.

Question 1 One of these readings is weight and the other is mass. Which one is which? Explain how you know this. There are several ways.

When you find the weight of an object it is a measurement based on the gravitational pull of the planet that you are on. In step **E)** gravity pulls the bar down on the platform which implies that this value is the *weight* - the more gravity, the harder the pull, the higher the value. In step **F)** gravity pulls on both sides of the pan balance so the amount of gravity doesn't matter. It would still balance out to the same value no matter how hard gravity would pull. Therefore this value is the mass. When you find the mass you are always comparing an unknown mass to an object that you already know the mass of (i.e. the slotted discs).

You can also know simply by looking at the units. *Newtons* are always for *weight* and *kilograms* (or *grams*) are always for *mass*.

Question 2 Which value will remain the same when you are on a different planet? Explain.

Question 3 In what direction does gravity always pull?

You are able to calculate the weight from the mass and vice-versa by using the following equation ...

$$W = mg$$

<p>W is the weight (in Newtons, N)</p> <p>m is the mass (in kilograms, kg)</p> <p>g is the acceleration due to gravity (m/s^2)</p>
--

On your planet the acceleration due to gravity is 9.8 m/s^2 . When you plug in for “g” it will always have a positive sign, *never a negative*.

- I)** Using the mass value in your chart, calculate the weight of the block and place it in the chart. Calculate the percent difference between the two weight values.
- J)** Please remove the black bar from the force probe.

More Equipment The other piece of equipment is called a *force table* and it is used to examine the idea of equilibrium. (See **Figure 2 on the next page**.) Each of the strings that are attached to the black ring on the table will represent a *tension* that is pulling on the ring. The ring is encircling a post. When the ring is exactly centered on the post then the system is in equilibrium.

Before you begin, you need to level the force table. On top of the post there is a level. (This “level on a post” can be removed from the force table, if necessary.) If you

look directly down on the force table you will see it. When the bubble is centered on the black circle the table is level. You can level the table by adjusting the height of the feet at the base of the table. See **Figure 2**.

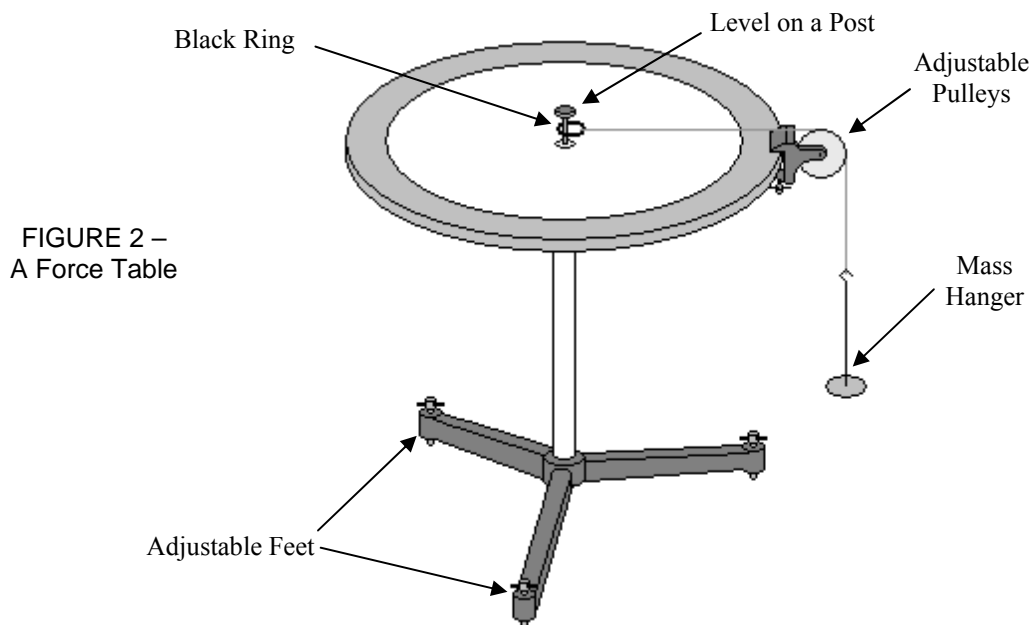

FIGURE 2 –
A Force Table

Part 2 – Tension As stated before, you have a tension acting on an object when a string or rope is attached to it. The tension will always *pull* away from an object. (You can't *push* anything with a string.) To begin, make sure the level post is in place and the black ring is encircling it.

A) If there are any pulleys attached to the table, then remove them. Also remove any mass hangers from the strings.

B) If you look down on the force table you will see degree marks around the edge of the table top. Place a pulley on the force table at 0° .

C) Take one of the strings that is attached to the black ring and place it over the pulley. Hang a mass hanger from this string. See **Figure 2**.

D) Place a *combined mass* of 100 g on this mass hanger. The *combined mass* should include the mass of the hanger which is always 50 g.

A *Free-Body Diagram* is a drawing that consists of a sketch of your object and all the forces acting on it. This includes ...

- A *vector* for each force - pointing in the direction that the force is acting
- *Labels* for each vector - so far we've discussed T for tension and W for weight
- An indication of which way you are choosing as a *positive direction*

E) You are going to consider the mass hanger and the extra mass as all one *object*. Draw a Free-Body Diagram (F.B.D.) for your *object*. Check with your TA to make sure it is correct.

If an object is continually at rest, then its acceleration is zero. This would make the net force on an object equal to zero, $\sum \mathbf{F} = \mathbf{0}$, according to Newton's 2nd Law. Under this condition we would say that the object is in *equilibrium* (or, more specifically, *translational equilibrium* but that's not an issue in this lab. It will, however, come up later in the semester for you.). Another way to think of equilibrium is that it is the state in which all of the forces acting on an object cancel each other out.

F) Apply Newton's 2nd Law to your object based on the F.B.D. that you drew. Is your object in equilibrium? How do you know this?

G) Using your equation, calculate the tension.

Your result from step **G)** should be telling you that for any strings on the force table the tension in those strings will be equal to the weight of the combined mass hanging from it. You will be using this idea throughout the rest of this lab.

Part 3 – One Dimensional Newton's 2nd Law Let's review and expand on the idea of equilibrium. For example, you've seen an object with two forces of equal magnitudes but opposite direction acting on it. **See Figure 3.** The net force along the x-axis will equal zero ($\sum \mathbf{F} = 30 + -30 = \mathbf{0}$, according to the sign convention shown) and we would say that the object is in equilibrium along the x-axis.

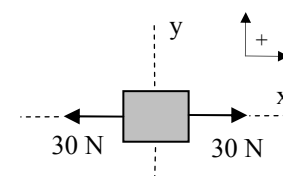

FIGURE 3 – Equal forces acting on an object

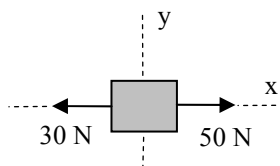

FIGURE 4 – Unequal forces acting on an object

However, let's say that we have an object with two forces of *unequal* magnitudes but opposite direction acting in it. **See Figure 4.** The net force along the x-axis will *not* equal zero ($\sum \mathbf{F} = 50 + -30 = 20$) and we would say that the object is *not* in equilibrium along the x-axis. For this case, what would the state of motion be?

A) Using the set-up that you had the force table in for **Part 2**, look from the side along the line of the string and make sure that the pulley is directly in parallel with the string and not at an angle. If it is not parallel then adjust the pulley so that it is. *Always do this whenever you position a string over a pulley.*

B) In its current state, the black ring should be pulling on the level post. Remove the level post and observe what happens to the black ring.

Question 4 After you removed the level post, was the ring in equilibrium? Explain in two different ways how you know the answer to this question.

C) Reset the system to the state it was in up through step **A)** above.

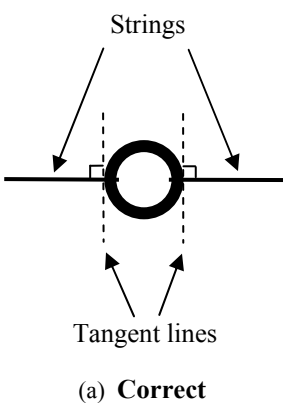

D) Place another pulley at 180° on the force table. NOTE: A line drawn through 0° and 180° is considered to be the x-axis.

E) Take another one of the strings that is attached to the black ring and place it over the pulley at 180°. Hang a mass hanger from this string. NOTE: Make sure to slide the string loops along the ring so that each string lines up with the center post. See **Figure 5a**. The strings need to come *directly* off of the ring, not at an angle. See **Figure 5b**. (Another way to think of it is that the strings should be perpendicular to tangents of the ring circle.) Adjust the strings if they are not.

F) Place a *combined mass* of 100 g on this mass hanger.

G) Remove the level/post and observe what happens to the black ring.

Question 5 After you removed the level, was the ring in equilibrium? Explain in two different ways how you know the answer to this question.

There are two ways to determine equilibrium. One way is to look at how the forces are acting on your object. If they cancel each other out then $\sum \mathbf{F} = \mathbf{0}$ and we have equilibrium. If they don't cancel out then we do not have a state of equilibrium. The other way is to look at the motion of the object. When you pulled the level in step **B**) the black ring started out at rest and accelerated until the hanger hit the table. If an object accelerates then according to $\sum \mathbf{F} = m\mathbf{a}$ there must be a net force acting on the object and therefore it is not in equilibrium. If the object does not accelerate then it is in equilibrium.

H) Reset the system to the state it was in up through step **G**) above.

I) Place an additional 20 g on the hanger at 180°.

J) Remove the level/post and observe what happens to the black ring.

Question 6 After you removed the level, was the ring in equilibrium? Explain in two different ways how you know the answer to this question.

Part 4 – Two Dimensional Equilibrium Now you are going to be dealing with forces that are acting along more than one axis. As an example let's say we have a situation as in **Figure 6**. Now there are three forces acting on a block. Is the block in equilibrium? Even though the forces on the x-axis cancel out (in equilibrium along the x-axis) there is still a force on the y-axis (not in equilibrium along the y-axis). So, overall, the block is not in equilibrium.

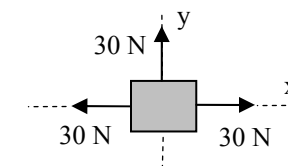

FIGURE 6 – Three forces acting on an object

In order to make the block in **Figure 6** be in equilibrium what would you need to do? You would need another force of magnitude 30 N acting downward on the block. You can also apply this idea to the components of vectors as well. Keep this in mind while you do this lab.

It is important to keep in mind that this equilibrium equation, $\sum \mathbf{F} = \mathbf{0}$, is a vector equation, meaning that it applies to the x -axis AND the y -axis separately (similar to the way that you applied the linear motion equations to each axis in projectile motion). In the last section we specifically dealt with forces acting along the x -axis. So, to be more specific, when we had equilibrium we should have written $\sum F_x = 0$. You would do the same for the y -axis. From this point on in the lab, make sure you specify which axis you are referring to.

A) Remove the 20 g mass from the hanger at 180° . (Your current system should have a *combined mass* of 100 g for each mass hanger.)

B) Place a pulley on the force table at 90° . NOTE: A line drawn through 90° and 270° is considered to be the y -axis.

C) Place a *combined mass* of 70 g on the hanger at 90° .

D) Remove the level post and observe what happens to the black ring. (If your system completely comes off the pulleys then something is out of alignment [your pulleys, your strings, how the strings are aligned with the black ring, etc.] Go back re-read the lab in the sections that you missed on how to align your system properly.)

Question 7 *Just after* you removed the pin, was the ring in equilibrium?

Question 8 *Just after* you removed the pin, was the ring in equilibrium on the x -axis? Explain your answer and be specific.

Question 9 *Just after* you removed the pin, was the ring in equilibrium on the y -axis? Explain your answer and be specific.

Question 10 Do you think that an object has to be in equilibrium along both axes in order to be able to say that an object is in equilibrium?

So, in order to say that an object is in equilibrium, $\sum \mathbf{F} = \mathbf{0}$, then both $\sum F_x = 0$ and $\sum F_y = 0$ must be true.

Part 5 – Vector Components In looking back at **Figures 3, 4, and 5**, you will see diagrams with forces acting on blocks. The forces are represented by *vectors*. The vectors in those diagrams are all either pointing parallel to the x -axis or the y -axis. Now you are going to be dealing with vectors that are pointing at an angle to either axis.

The way in which you deal with vectors at an angle is by breaking them into *vector components*. One component is parallel to the x -axis and the other is parallel to the y -axis. A good way to think of components is that they are projections of the main vector onto either the x -axis or the y -axis, just like casting a shadow.

In **Figure 7a** (on the next page), you see a vector \mathbf{F} that is at angle θ with respect to the x -axis. We want to break this vector into components. Let's say that we have a very bright light source that is very far away (like the sun). We put that light source

to the right of **F** and shine the light on **F**. **F** will cast a shadow on the y-axis that looks like a shorter version of **F**. This shadow is the y-component of **F** and we label it as **F_y**. See **Figure 7b**.

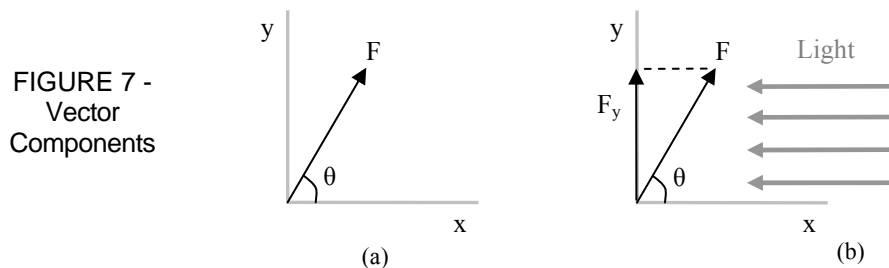

Similarly, let's say that we put the same bright light source above **F** and shine the light down on **F**. **F** will cast a shadow on the x-axis that looks like a shorter version of **F**. This shadow is the x-component of **F** and we label it as **F_x**. See **Figure 8a**.

Any vector can be moved anywhere and it will remain the same vector as long as you don't change its magnitude (i.e. its number value or graphically, its "length") or its direction. So, in **Figure 8b**, we combine together the three vectors in the same diagram, also moving the y-component over to the right so that the three vectors form a right triangle.

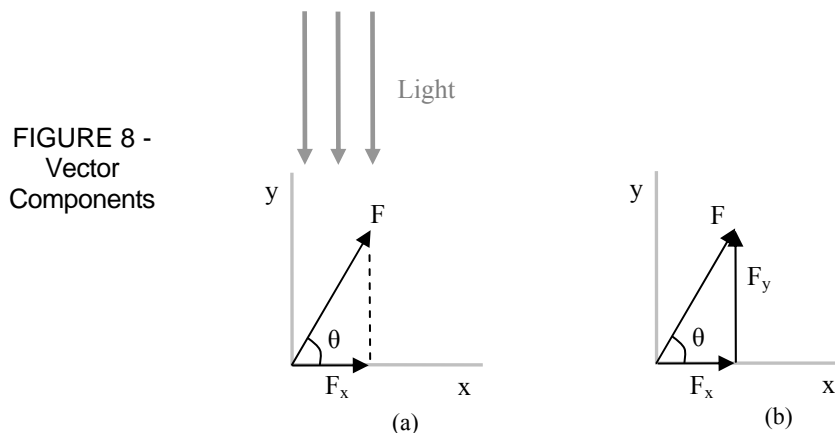

Forming a right triangle with the vectors will allow us to use trigonometry as well as the Pythagorean Theorem when we do calculations. If we know **F** and **θ** then we can use *sin* and *cos* to calculate the values of the components. In line #1 (below) we choose the appropriate trig functions for finding the component values. In line #2 we do some algebra to solve for the components.

$$\#1 \quad \Rightarrow \quad \sin \theta = \frac{F_y}{F} \quad , \quad \cos \theta = \frac{F_x}{F}$$

Solving for F_y ...

Solving for F_x ...

$$\#2 \quad \Rightarrow \quad F_y = F \sin \theta \quad , \quad F_x = F \cos \theta$$

Notice in solving for the components, they will always equal the magnitude of F times either \sin or \cos of the angle. (You will never use \tan to solve for a component.) So, you can always skip line #1 and just write down line #2 since the only algebra you will be doing from #1 to #2 is to multiply both sides by F no matter if you are using \sin or \cos . The rest of this lab will automatically skip step #1 so if you are confused about this then grab your TA and ask to explain.

A) Remove the pulleys and mass hangers at 0° and 90° (leave the one at 180°). Place a pulley with a string slung over it at 60° . Suspend a mass hanger from this string and put a *combined mass* of 150 g on it. This is going to represent vector \mathbf{T} (for tension). You are going to use the force table to find the components of \mathbf{T} . NOTE: The mass on this hanger will remain constant. You will not be adding any more mass to it for this part of the lab.

B) Also place a pulley, string, and mass hanger at 270° . These will represent vectors \mathbf{T}_1 and \mathbf{T}_2 , respectively. You will see that these will be equivalent to \mathbf{T}_x and \mathbf{T}_y , respectively (the components of \mathbf{T}). It is important that you notice that the strings at 180° and 270° are aligned with the x-axis and the y-axis, respectively.

C) Place the appropriate mass on each mass hanger until the system is in equilibrium. Read below before starting this process

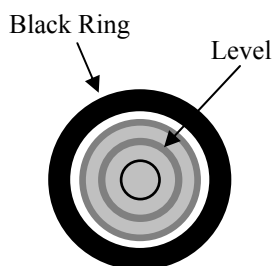

Centered

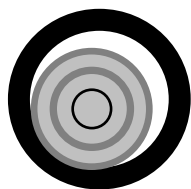

Not Centered

FIGURE 9 -
Ring Alignment

Determining Equilibrium

1. Your system will be in equilibrium when the black ring that the strings are tied to is centered on the level. See **Figure 9**. You will have to look from above, straight down on the force table to determine this.
2. Before determining equilibrium, make sure to slide the string loops along the ring so that each string lines up with the level post. (Just like you did in **Part 3**.) See **Figure 5**.
3. When you think that you have the correct combined masses for equilibrium, lift the ring up to the bottom of the level on the post and then release it. The ring will oscillate briefly. If the ring does not center itself, then you need to make further adjustments to the combined mass. After you make your adjustments then lift the ring again and release it. Repeat this until the ring stays centered after lifting and releasing several times. You can also try just hitting the force table (like you are playing a conga). If the ring doesn't move then you know it's centered and in equilibrium.

In examining a birds-eye view Free-Body Diagram of the ring, we see that there are three forces acting on it (ignoring the weight of the ring). See **Figure 10a**. In breaking **T** up into components we get **Figure 10b**.

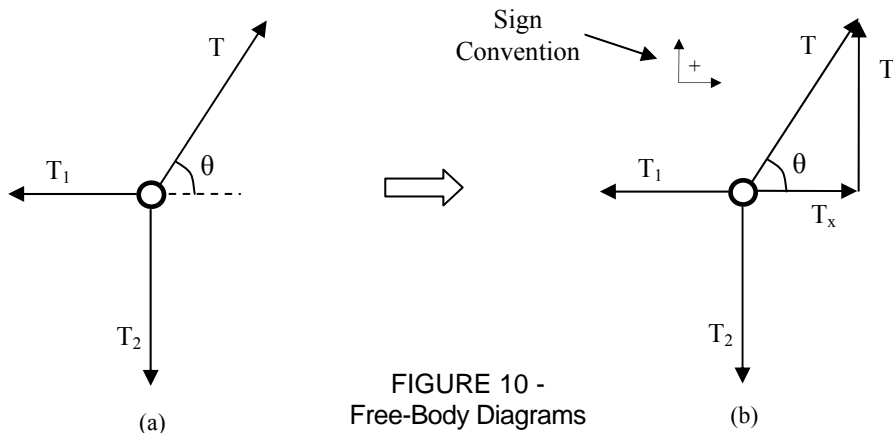

Using the sign convention shown in **Figure 10b**, we apply the equilibrium equations for the both axes ...

$$\begin{aligned} \Sigma F_x &= 0 & \Sigma F_y &= 0 \\ T_x - T_1 &= 0 & T_y - T_2 &= 0 \\ T_x &= T_1 & T_y &= T_2 \end{aligned}$$

In the *x-axis summation*, notice that **T_x** is positive because it is pointing in the positive direction according to the sign convention. See **Figure 10b**. Also, notice that **T₁** is negative because it is pointing in the negative direction. The same idea is applied to the *y-axis summation*. The results of the summations are that **T₁** and **T₂** are equal to the *x*-component and the *y*-component of **T**, respectively. Now you are going to do some calculations to verify that.

D) Make a chart in your lab report like **Chart 2**.

	T	T_x	T₁	%	T_y	T₂	%
Part 5							
Part 6							

CHART 2

E) Earlier, you determined that **T** is equal to the combined *weight* of the mass hanger and the extra masses that you placed on it. This is for the hanger at the pulley at 60°. Calculate **T** and put this value in the chart. Make sure your units are Newtons.

F) Using the equations discussed at the bottom of page 5 - 7, calculate **T_x** and **T_y**. Place these values in the chart.

G) T_1 and T_2 are equal to the combined *weight* of the mass hanger and the extra masses that you placed on them. These are for the hangers at the pulleys at 180° and 270° . Calculate T_1 and T_2 and put these values in the chart. Make sure your units are Newtons.

H) We concluded earlier that $T_x = T_1$ and $T_y = T_2$. To verify this, calculate a percent difference for each pair and place these values in the chart. If you get percents that are greater than 10%, then you made a mistake somewhere. Go back and find your error.

Part 6 – Vector Components, Again You are now going to do **Part 5** over again but on your own. You will just have different T and θ values.

A) Remove all pulleys from the force table. Remove all mass hangers from the strings.

B) Place a pulley with a string slung over it at 155° . Suspend a mass hanger from this string and put a combined mass of 200 g on it. This is going to represent vector T .

C) Determine where you are going to place the other two pulleys to find the components of T . NOTE: The location of one pulley has to be along the *x-axis* (either at 0° or 180°) and the other has to be along the *y-axis* (either at 90° or 270°).

D) Place the appropriate masses on these two pulleys in order to achieve equilibrium.

E) Draw a Free-Body Diagram for the ring. Make sure to label the vectors and show the components of T . Check with your TA if you are not sure if you are correctly drawing your Free-Body Diagram.

F) Do your calculations to fill in the rest of **Chart 2**. (NOTE: Make sure you are using the correct angle that is inside of your component triangle.) If you get percents that are greater than 10%, then you made a mistake somewhere. Go back and find your error.

Part 7 – Equilibrium For Three Vectors In this part of the lab you will be given two vectors and asked to find a third one that will create equilibrium in the system.

A) Remove all pulleys from the force table. Remove all mass hangers from the strings. Make a chart in your lab report like **Chart 3**.

Measured Method		Components Method				%
T_3	θ	T_{3x}	T_{3y}	T_3	θ	

CHART 3

B) Place a pulley with a string slung over it at 0° . Suspend a mass hanger from this string and put a *combined mass* of 150 g on it. This is going to represent vector T_1 . NOTE: This mass and location should not be altered for the rest of **Part 7**.

C) Place a pulley with a string slung over it at 145° . Suspend a mass hanger from this string and put a *combined mass* of 300 g on it. This is going to represent vector T_2 . NOTE: This mass and location should not be altered for the rest of **Part 7**.

D) Add a third pulley, hanger, and extra masses somewhere along the edge of the force table so that the system is in equilibrium. This is going to represent vector T_3 . Use what you have learned so far and think about what components you need to balance. You will have to play around with both the location of the pulley (i.e. θ) and the mass you put on the hanger. The system will be affected by masses as small as 2 g so be precise when you determine if the system is in equilibrium. Use methods described in **Determining Equilibrium** from page 5 - 8. Once you reach equilibrium, put your T_3 and θ values in **Chart 3** under **Measured Method**.

E) Draw a Free-Body Diagram for the ring. (NOTE: Refer back to **Figure 10b** if you are having trouble with this. Your F.B.D will be *similar* to **Figure 10b** but *not* the same.) Make sure to label your vectors and show the components where appropriate. NOTE: There will now be more than one vector in your F.B.D. that needs to be broken into components.

F) Show your summation of forces for both axes. Do this in variable form, i.e. do not plug in any numbers yet. (NOTE: Refer back to the summations on page 5 - 9 if you are having trouble with this. Your summations will be *similar* to the summations on page 5 - 9 but *not* the same.)

G) Now that you have your equations, plug in your numbers and solve for T_{3x} and T_{3y} . Make sure you are plugging in the correct angle into your equations. Put your component values in **Chart 3** under **Component Method**.

H) Calculate the magnitude of T_3 by using the Pythagorean Theorem on your component triangle. Place this value in the chart.

I) Calculate the direction of T_3 by using a *tan* function on your component triangle. Place this value in the chart.

J) Calculate a percent difference between the magnitudes of your T_3 and place these values in the chart. If you get percents that are greater than 10%, then you made a mistake somewhere. Go back and find your error.

K) Please remove all pulleys and mass hangers from the force table before you leave.

What You Need To Turn In:

On a separate sheet of paper answer all of the questions, include all of the charts that you are asked to draw, and also the correctly labeled Free-Body Diagrams.