

Lab 6: Forces – Part 2

What You Need to Know

Introduction

This is the second part of the lab that you started last week. If you happen to have missed that lab then you should go back and read it first since this lab will assume you already know about certain concepts and will not re-explain them. For example, you will need to already understand Free-Body Diagrams (F.B.D.s) and how to apply Newton's 2nd Law to them.

Last week we discussed weight, tension, and equilibrium. This week you will still be using these ideas but you will also be introduced to some new forces as well as discussing non-equilibrium situations.

What You Need to Do

Part 1 – Normal Force

In geometry a *normal line* is a line that is perpendicular to a surface. In physics we have a force called a *normal force*, F_n , because it always acts on an object perpendicularly to the surface that it is on. It also always points *away* from the surface, never towards. It is known as a *contact force* because you will only have a normal force when the object is touching another object or surface. For example, last week you drew an F.B.D. for a hanging mass. In the diagram you had a tension and a weight but no normal force because the hanger was suspended from a string and *not* resting on the table.

Question 1 :

Is weight a contact force? If yes, then does an object have a weight when it is flying through the air? If no, then explain why you think it's not.

- A) You should have on your table the same force probe and platform that you used last week. Place the probe on the table so that the platform is facing up.
- B) Open up the file called **FORCE PROBE** from this lab's supporting files. Push the ZERO button to zero out the probe.

C) Place the black metal bar on the platform. **See Figure 1.**

Figure 1 – A Force Probe with a Metal Bar

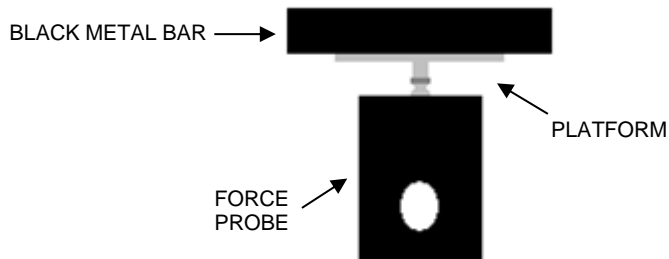

D) Draw an F.B.D. of the bar. Make sure that it is appropriately labeled. If you are unsure about this, then check with your TA.

Question 2

Is the bar in equilibrium? Explain how you know this.

E) Apply Newton's 2nd Law to the bar and solve for the normal force algebraically (i.e. no numbers).

Question 3

The result you should have gotten from **E)** is that the normal force equals the weight of the bar. Do you think that the normal force will *always* equal the weight?

Question 4

Do you think the probe is reading the weight of the bar or the normal force acting on the bar? Explain why you think this.

- F) With the bar still on the platform, lift the probe off of the table and, as you watch the reading on the computer, tilt the probe. **See Figure 2.**

Figure 2 – A Force Probe Tilted

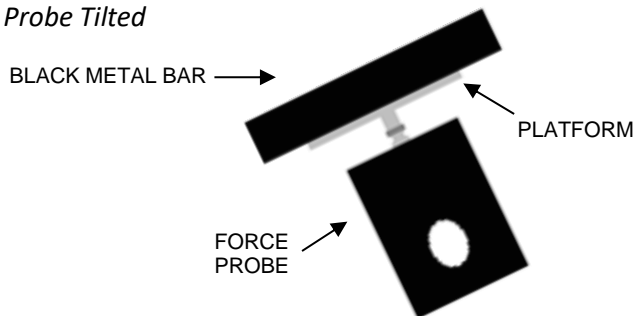

- G) Describe what happens to the reading as you increase the angle.

Question 5

Referring back to **Question 4** and based on what happened to the reading when you tilted the probe, is the probe reading the weight or the normal force? If you think it's the normal force, explain why you think the normal is changing. What is it dependent on? If you think it's the weight, explain why you think the weight is changing.

- H) Draw an appropriately labeled F.B.D. for the bar when it is at an angle. In your drawing, rotate your x -axis so that it is *parallel* to the platform and rotate the y -axis so that it is *perpendicular* to the platform. **See Figure 3.** Show the angle θ as well as any components that you may need.

Figure 3 - Rotated Axes on Your Block

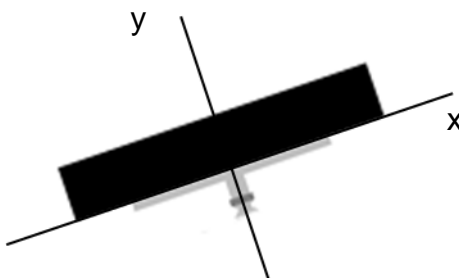

Check with your TA if you are having trouble.

- I) Apply Newton’s 2nd Law to the y-axis and solve *algebraically* for the normal force. (Use the component/trig ideas from last week.)

Question 6

Does the weight equal the normal force when the platform is at an angle? Does this answer agree with your answer from **Question 3**?

- J) Please remove the black bar from the force probe.

Part 2 – Two Objects, Horizontal Surface

When you are dealing with a rotating pulley that is approximately massless and frictionless (like the ones you are using in lab) then you can approximate the tension on either side of the pulley to be the same.

- A) Close out of **Force Probe** and open the file called **MOTION SENSOR** on the computer.
- B) Make a table in your lab report like [Table 1](#).
- C) Go to one of the digital mass scales in the lab and measure the mass of the cart along with the signal bouncer.

NOTE: If a fan is attached to the cart then remove it before you measure the mass.

Place the value in the table.

Table 1 – Part 2 and 3 Data

	Part 2	Part 3
Cart Mass		
Hanging Mass		
“a” – Trial 1		
“a” – Trial 2		
“a” – Trial 3		
Average “a”		
“T” Hanging		
“T” Cart		
%		

Figure 4 - Track Set-up (NOT DRAWN TO SCALE)

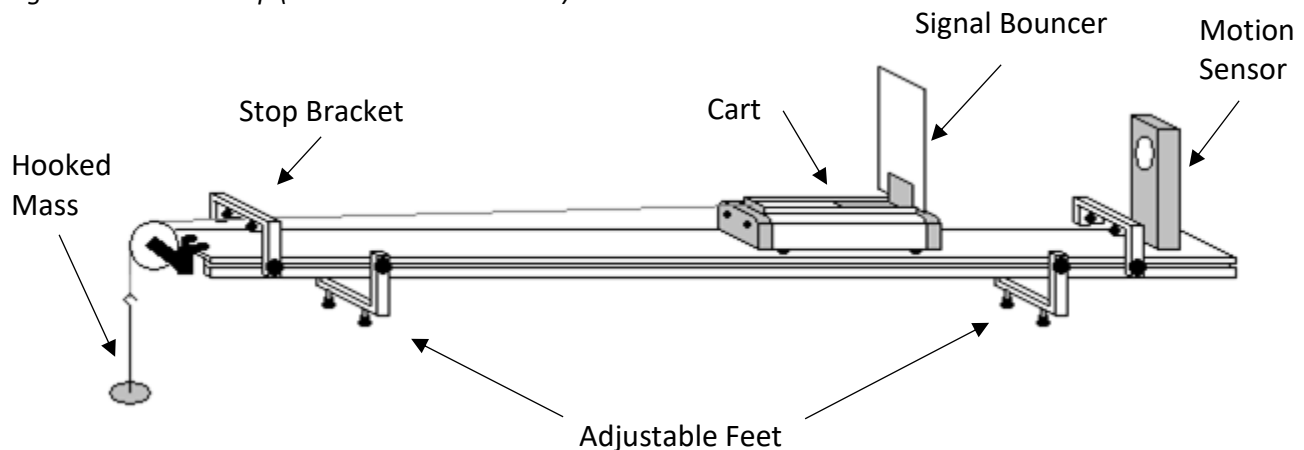

D) Prepare the cart for data collection:

- Place the cart on the track about 50 cm from the motion sensor. *This will always be the starting position of the cart.*
- There should be a string attached to the cart via a paperclip. Have the string slung over the pulley with the other end attached to the mass hanger. **See Figure 4.**
- Make sure that the string goes through or under the stop bracket.
- Once you have done all this the cart will want to move but you should hold it in place.
- Verify there is a small box on the floor directly below the mass hanger. The box will “catch” the hanger when it falls.
- Have one of the people in your lab group at the end of the track to catch the cart and prevent it from slamming into the stop bracket.** Once you release the cart it will have a high acceleration so make sure you catch it. *If you break a cart you will have to pay for it.*
- Hang a hooked *mass* of 200 g on the string. Place this value in the table.

E) Push COLLECT on the computer. Wait until you hear the motion sensor begin to click and then release the cart.

- Catch the cart...

F) Highlight the mostly straight region of the graph with your mouse by holding and clicking. Push the “Linear Fit” button. This will give several pieces of information including the slope of the line. What does the slope of a v vs. t give you? If you don’t remember then go back and read the **Acceleration** lab. Record this value in the table.

- G) Repeat **D)** and **E)** two more times and place these values in the table. Calculate an average value and place it in the table. Place the hooked mass on the table so that it doesn't pull on the cart anymore.
- H) Draw appropriately labeled F.B.D.s for the cart and the hanging mass. NOTE: Make sure that, when you label your positive directions, they always point in the direction of motion for each object.
- I) Apply Newton's 2nd Law to both objects for as many axes as possible (any axis for each object that has forces or force components)
- J) Solve each applicable equation for the tension, **T**, *algebraically*. Solve each applicable equation for the normal force, **F_n**, *algebraically*.
- K) Plug in the masses from your table as well as any other constants you need and calculate the tension from each equation. Place these values in the table.
- L) Calculate a percent difference between the two tension values and place this in the table. If your percent is greater than 15% then you made a mistake. Go back and find your error.

Question 7

The tension values should have come out exactly the same for either side of the pulley (as mentioned at the beginning of this section). Why do you think they didn't? Is it just a systematic error, bad data taking, or is it something else?

Part 3 – Two Objects, Angled Surface

You are now going to follow the same procedure as the last section but now you will be doing it with the track at an angle. See **Figure 5** on the next page.

Question 8

How do you think angling the track will affect your results? Which results will change?

- A) There is a wood block on your table with an arrow on the edge of it. Place it under the adjustable foot that is closest to the pulley so that the arrow is pointing *up*.
- B) Using the same masses, repeat the procedure you used to find your acceleration from [Part 2](#) – Two Objects, Horizontal Surface. The only thing that has been changed is the angled track. Record your acceleration values in the table and find your average.
- C) Draw appropriately labeled F.B.D.s for the cart and the hanging mass. Make sure you take into account that the track is at an angle. Looking back at [Part 1](#) – Normal Force might help.

Question 9

Explain in detail (not just “because we changed the angle”) why your acceleration value came out less than the one from [Part 2](#) – Two Objects, Horizontal Surface. HINT: The answer is in your F.B.D. of the cart.

- D) Apply Newton’s 2nd Law to both objects for as many axes as possible.
- E) Solve each applicable equation for the tension, **T**, *algebraically*. Solve each applicable equation for the normal force, **F_n**, *algebraically*. You will plug in numbers later.

- F) In order to calculate the tension from these equations you need the angle, θ , of the track. You are going to use a right triangle (in black in **Figure 5**) where the hypotenuse is the 100 cm between the feet and the height, h , is the height of the block. Remove the block from under the foot of the track and use the ruler on the track to measure its height. Using a trig function, calculate the angle, θ .

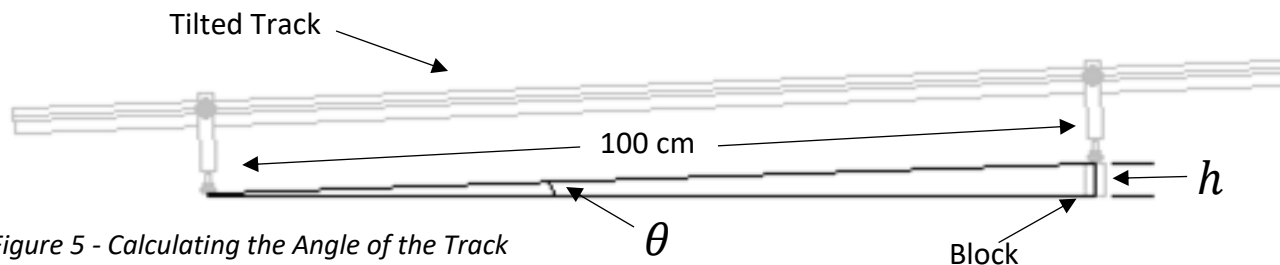

Figure 5 - Calculating the Angle of the Track

- G) Plug in the masses from your table, the angle you just calculated, as well as any other constants you need and calculate the tension from each equation. Place these values in the table.
- H) Calculate a percent difference between the two tension values and place this in the table. If your percent is greater than 15% then you made a mistake. Go back and find your error.

Question 10

How does the normal force on the cart from [Part 2](#) – Two Objects, Horizontal Surface and [Part 3](#) – Two Objects, Angled Surface differ? What caused them to be different?

Part 4 – External Force, A Person

An external force is a force usually exerted by a person or sometimes another object. This part is going to deal with you pushing on the bar as an external force.

- A) On the computer, close out of **Motion Sensor** and re-open **FORCE PROBE**.
- B) Place the force probe on the table with the platform facing up. Put the black metal bar on it.
- C) While observing the readout on the computer, push down on the bar with your finger. Try to push with a constant force. If you've had too much coffee today and can't keep your hand steady then have someone else try. What happens to the reading relative to when you weren't pushing down on the bar?
- D) Draw an F.B.D. of the bar. Label the force due to your finger as F_{ext} .
- E) Apply Newton's 2nd Law to the bar and solve *algebraically* for the normal force.

Question 11

Does your equation from **E)** agree with your answer from **C)**? Explain.

Your results should also verify that the reading on the computer is *not* giving you a measurement of the weight on the platform. You saw this in [Part 1](#) – Normal Force as well. The reading is always giving you the normal force.

- F) Describe two physical situations in which $F_n \neq W$.

Part 5 – External Force, A Fan

On your lab table there is a battery-operated fan that is now going to act as an external force on the cart.

m	a	$F_{\text{ext.}}$

Table 2 – Part 5 Data

- A) Make a table in your lab report like **Table 2**.
- B) Take the fan to the back of the lab and measure its mass. Add this to the mass you measured earlier for the cart and place this value in the table.
- C) Using two rubber bands, secure the fan to the cart with the arrow on the fan pointing towards the signal bouncer. Make sure that the rubber bands are not touching the wheels of the cart.
- D) Close out of **Force Probe** and open **MOTION SENSOR #2**.
- E) Remove the block from under the track so that it is now horizontal. Place the cart (without the string attached) on the track *far* from the motion sensor and with the arrow pointing *towards* the motion sensor. NOTE: The longer you leave the fan on the worse your results are going to be. As the battery drains the fan spins slower and you need to have it as constant as possible. So, shut the fan off as soon as you are done.
- F) Make sure someone is ready catch the cart before you release it. Push COLLECT on the computer, turn on the fan, and release it.
- G) Highlight the mostly straight region of the graph. Push the “Linear Fit” button. Omit the negative sign and record your acceleration in the table.
- H) Draw an F.B.D. of the cart and fan as one object. Label the force due to the fan as $F_{\text{ext.}}$.
- I) Apply Newton’s 2nd Law to your object and calculate the external force due to the fan. Record this value in the table. This is the constant (hopefully) force due to the fan. *You will use it in the next part of the lab.*

Part 6 – External Force With Multiple Objects

You will now be doing [Part 2](#) – Two Objects, Horizontal Surface (earlier in the lab) over again but with an external force due to the fan acting on the cart.

Question 12

With everything set the same as in [Part 2](#) except for the fan acting on the cart, in which direction will the cart move? How do you know this? Explain. (You should be able to tell just by comparing two numbers. Which ones?)

- Set up your system the same as in [Part 2](#) except now with the fan acting on the cart. The arrow should again be pointing *towards* the signal bouncer.
- Make sure you have a catcher ready. Hold the cart at starting position. Push COLLECT on the computer, turn on the fan, and release the cart.
- Make a table in your lab report like **Table 3**.

Table 3 – Part 6 Data

$a_{\text{meas.}}$	$a_{\text{calc.}}$	%

- Measure the acceleration from the graph and put it in the table.
- Draw an appropriately labeled Free-Body Diagrams for the cart/fan and the hanging mass.

- Apply Newton's 2nd Law to both objects. You don't need to do one for the cart/fan on the y-axis.

- G) Solve for the tension algebraically in both equations. Set the two equations equal to each other and then plug your numbers in to calculate the acceleration of the system. Put this value in the table.
- H) Calculate a percent difference between the two acceleration values and place this in the table. If your percent is greater than 15% then you made a mistake. Go back and find your error.
- I) Please remove the fan from the cart as well as the attached string. Thanks!

What You Need To Turn In:

Answer all the questions asked in the lab. Make sure you include all the tables as well. You must show your work for all of the Newton's 2nd Law equations.