

Lab 7: Energy

Experiment for Physics 211 and 225 Lab at CSUF

What You Need To Know:

The Physics

This lab is going to cover all of the different types of energy that you should be discussing in your lecture. Those energy types are kinetic energy, gravitational potential energy, and spring potential energy. In the following paragraphs, we will discuss when each of these energies is present.

Kinetic Energy

If an object is moving then it has *kinetic energy*. This implies that the equation for kinetic energy is based on the speed of an object ...

$$KE = \frac{1}{2}mv^2$$

KE is the kinetic energy of an object (in Joules, J)

m is the mass of the object (in kilograms, kg)

v is the speed of the object (in meters per second, m/s)

Equation 1 –
Kinetic
Energy

Note that the unit of the kinetic energy is a *Joule* which is the unit for all energy types in physics. Also, any type of energy is scalar in nature (i.e. there is no direction associated with it.).

Gravitational Potential Energy

Energy that is based on the location or displacement of an object is *potential energy*. This type of energy is based on a reference point (your origin). The equation for *gravitational* potential energy is ...

$$PE_g = mgh$$

PE_g is the gravitational potential energy (in Joules, J)

m is the mass (in kilograms, kg)

g is gravitational acceleration (in meters/second squared, m/s^2)

h is location of your object (in meters, m)

Equation 2 –
Gravitational
Potential
Energy

For gravitational potential energy you can choose your reference point at any location that you want. This has the interesting effect that if you are asked, “What is the gravitational potential energy of your object”, then you can always answer with “Zero”. Since you can place your reference point at any location that you wish you can always just place it at the object. In this case your location is zero ($h = 0$) and therefore so is your potential energy. The problem is that the question is not specific enough. Whenever you are asked for the potential energy it has to be asked relative to some location. For example, “What is your potential energy relative to the floor?” The first thing you should always do when working an energy problem is to define your origin.

Springs

The type of spring that you will be using in physics is a special type of spring that you can extend *and* compress [unlike a Slinky (™ Hasbro) which only extends and does not compress]. Usually, there will be an object attached to the spring. The location of the object when the spring is *neither* extended nor compressed is called equilibrium. See [Figure 1a](#). The dashed line represents the location of equilibrium.

Figure 1 – Spring and Box

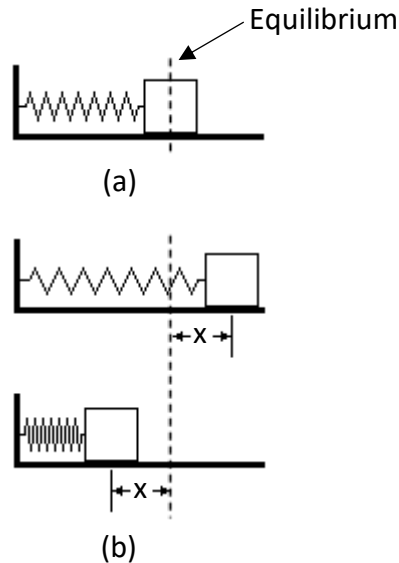

When the spring is extended or compressed there will be a force acting on the object due to the spring. This force is defined by an equation called Hooke's Law ...

$$F_{sp} = -kx$$

F_{sp} is the force of the spring (in Newtons, N)	<i>Equation 3 – Hooke's Law</i>
k is the spring constant (in Newtons per meter, N/m)	
x is the displacement from equilibrium (in meters, m)	

The spring constant, k , is a measurement of the force acting on the object relative to how far the spring is compressed or extended. Basically, it is the measurement of the stiffness of the spring. The displacement, x , is the distance that the object moves relative to equilibrium, extended *or* compressed. See [Figure 1b](#).

Spring Potential Energy

As was stated before, potential energy is based on the location of the object. Spring potential energy is no different ...

$$PE_{sp} = \frac{1}{2}kx^2$$

PE_{sp} is the spring potential energy (in Joules, J)	<i>Equation 4 – Spring Potential Energy</i>
k is the spring constant (in Newtons per meter, N/m)	
x is the displacement from equilibrium (in meters, m)	

Since the displacement, x , can be either to the left or to the right of equilibrium, the spring will have energy stored in it regardless if it is extended or compressed.

Conservation of Energy

The total energy for a system will be constant when there are *no* non-conservative forces acting on it. The non-conservative forces that you need to concern yourself with are friction forces and external forces (like someone pushing on a box). If you don't have these forces acting on your system, then you have the state of *conservation of energy* (CoE). The equation for CoE is ...

$$KE_I + PE_I = KE_F + PE_F$$

The subscripts of **I** and **F** stand for initial and final. This equation is the main idea behind CoE. All of the initial energy in your system, whether it's kinetic energy or potential energy (any type, gravity or spring), is equal to all of your final energy.

The initial and final locations in your system are left up to you to decide. This is an idea that students have some trouble with. It is, however, the key to making CoE an easy idea, especially if you have some kind of complicated motion happening in your system.

For example, let's say that you are on a roller coaster that is totally *frictionless*. The car is going to be moving along from **Point A** to **Point B** then **Point C**. See [Figure 2](#).

Figure 2 – Roller Coaster

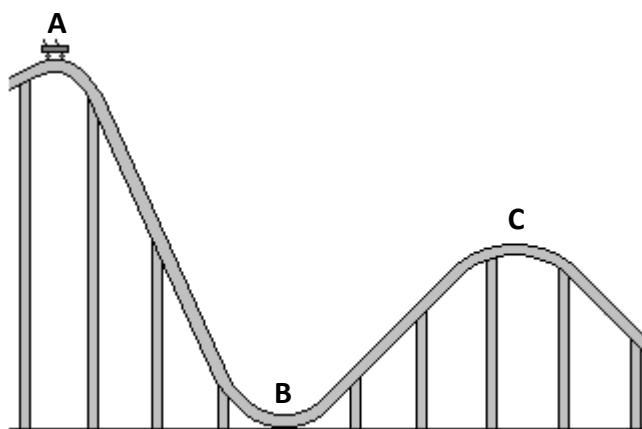

A roller coaster car is never pushed along so you can use CoE. When applying the CoE equation you need to decide where you are going to call your initial and final points. For example, you can say that the car starts at **Point A** and ends at **Point B** or you can say that the car starts at **B** and ends at **C**. Your kinetic and potential energies at these points are all going to be very different. Some will have zero *kinetic energy*. Some will have zero *potential energy*.

This may sound very obvious but it's an idea that students get wrong quite often. This lab is going to stress this idea and ask questions relating to it.

What You Need To Do:

The Equipment

You've seen the equipment for this lab before. You'll just be using it in a different way. For example, you will be using a motion sensor. However, you won't find it on the table. It's above your head. You'll also be using a track and cart but now you will be using carts with a spring launcher on one end.

Part 1 – Conservation of Energy With a Bag

In this section of the lab you will be dropping a bag from a certain height. A motion sensor will track the bag as it falls from a release point (however high you can reach) to 1 meter above the floor. We are defining location "zero" at the floor. So, the location, h , is with respect to the floor. The motion sensor has been calibrated so that it agrees with this system.

- A) For this section you'll take turns using the free fall setup at the smartboard near the front of the room. If the setup is occupied move on to parts 2 and 3 until its available. Unless your instructor directs you otherwise.

Question 1

Based on what was discussed in the introduction, what types of energy will you be using for this situation? For each type, explain how you know you will be using it.

- B) Open the file called **ENERGY**.
- C) Make a table in your lab report like **Table 1**.

Table 1- Part 1 Data

h_i	PE_i	h_f	PE_f	v_f	KE_f	E_i	E_f	%
		1.0						

- D) Collect Free fall data:
- One member from your group should stand close to the computer so there is no interference with the motion sensor.

- b. Another member of your group needs to climb on the stool and hold the bag directly below the sensor (but not closer than 0.40 m).
- c. Push COLLECT on the computer and watch the screen until you see a line on the graph. When you see a *horizontal* line release the bag by letting your hand fall away from it. **NOTE: It helps to hold the bag at your fingertips. Also, do not throw the bag up first.**

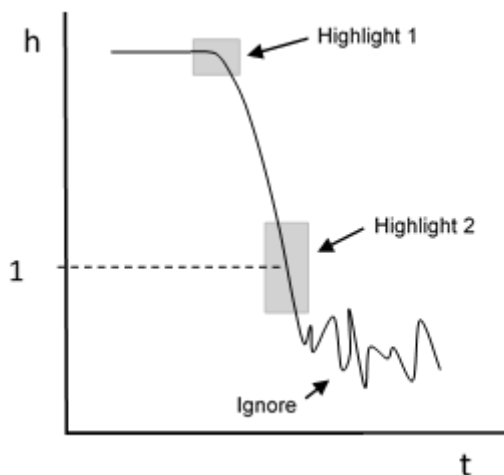

Figure 3 - h vs. t graph

- d. You want to get a smooth curve in the top and mid section of your graph as shown in [Figure 3](#). If you don't then repeat the measurement focusing on getting your hand out of the way of the sensor as soon as you release it.
 - e. If you can't get a nice curve then grab your instructor for help.
- E) We are going to define the *initial point* in the system as the point at which you drop the bag. State what kind of energy you have at this point and explain how you know this.
- F) We are going to define the *final point* in the system at the point at which the bag is 1 meter from the floor. State what kind of energy you have at this point and explain how you know this.
- G) Highlight the graph in the area for when you released the bag. **See Highlight 1 in [Figure 3](#)**. There are two shades of highlighting on this software. The darker shade should be like the one in the figure above. This happens when you move the mouse in 2 dimensions on the screen.

- H) Push the button on the screen labeled STAT. A window will pop-up that has a reading labeled as “max”. Record this value in the table as h_i . Close out of the pop-up window.
- I) Highlight the graph in the area for when the bag is at 1 meter. **See Highlight 2 in [Figure 3](#)**. Make sure you highlight the line from *at least* 1.2 m to 0.8 m.
- J) Push the zoom-in button on the screen (a little magnifying glass with a “+” sign). This will zoom in on your highlighted area.
- K) Once you’ve zoomed, highlight the graph from 1.2 m to 0.8 m. If this range is not on the screen then zoom back out (a little magnifying glass with a “-” sign) and try again.
- L) Once you have the correct highlighted area, push the “R=” button. This will give you a good approximation to the slope of the line at 1.0 m (right in the middle of the range). You used this same idea in the **Acceleration** lab doing the free-fall part, FYI. Record this value in the table.
- Note if you can't get a good measurement around 1.0m you can use a different location, just get $\pm 0.2m$ around what you pick. So if you need to use 1.2 make sure you highlight 1.0 to 1.4. Be sure to use the new height you picked to replace 1.0m in you calculations.*
- M) Measure the mass of the bag using the digital scales in the room.
- N) Using your data, calculate the potential energy of the bag at the initial and final locations. Put these values in the table.
- O) Using your data, calculate the kinetic energy of the bag when it was at the final location. Put this value in the table.
- P) Calculate the initial and final total energies and put these values in the table. Refer back to your answers from **D)** and **E)** if you having trouble with this.
- Q) Calculate a percent difference and put this value in the table. If you get a percent difference that is greater than 10% then go back and find your mistake.

Part 2 – Hooke’s Law

The cart on your table has a spring launcher that you will use to launch the cart along the track. In this section you will measure the spring constant of the spring.

- A) Close out of **Energy** and open the software **GRAPHICAL ANALYSIS** or **Excel**.

B) Make a table in your lab report like **Table 2**.

Table 2 – Part 2 Data

m	x_F	x	F_{sp}
200 g			
400 g			
600 g			
800 g			
x_I			
k			

C) Take the cart and stand it on end. Make sure that the spring pillar is NOT compressed. See [Figure 4](#). NOTE: At this point the pillar should NOT be compressed.

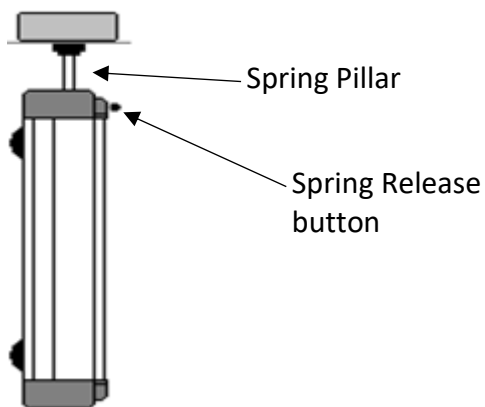

Figure 4 – Cart Standing on End

- D) Using the ruler, measure the distance from the table top to the top of the pillar. This is the initial location of the pillar. Put it in the table as x_I .
- E) Carefully place a total of 200 g on the pillar. This will compress the spring.
- Tap the mass to make sure that it is down as far as it wants to go.
 - Carefully press the spring release button to make sure its not held down.

- F) Using the ruler, measure the distance from the table top to the top of the pillar/bottom of the bottom mass. This is the final location of the pillar x_F to place in Table 2.
- Be as precise as you can be with this, you can estimate to the nearest half millimeter.
- G) Calculate the compression distance of the spring by ... $x = x_I - x_F$ and place this value in the table.
- H) Repeat this procedure for a total mass of 400 g, 600 g, and 800 g.
- When you stack the masses alternate the location of the slots so that the masses don't become lopsided and make the cart fall over.
 - Be sure to add the mass slowly and make sure you don't knock over the cart.
- I) The F_{sp} in the table is the force due to the spring. Using what you've learned in the Force labs determine F_{sp} and place the values in the table.
- Use F.B.D.s and summations. Also, there is no normal force, it's the spring force.
 - Hint: It involves calculating the weight W .
- J) Place the values for the spring force in the y-column on GRAPHICAL ANALYSIS or Excel. (Make sure that your units are Newtons.) Place the values for the displacement in the x-column.
- K) Push the "Linear Fit" button to determine the slope of the line or make a graph and add a linear trendline, then show the equation in Excel. This is also the spring constant, k . Put this value in the table. You will be using it later.
- L) Double check the units on your k value. Make sure every part is in meters, seconds, and kilograms

Question 2:

Explain in detail using an equation why the spring constant is equal to the slope of the line.

Part 3 – Conservation of Energy With a Cart

You are now going to examine the types of energy involved in launching the cart. With the launcher armed you are going to place the cart against the wall. When launched, the cart will shoot out and eventually stop. The initial point will be right before the cart is launched. The final point will be right after the cart is launched and the spring is not compressed anymore when the cart is moving.

Question 3:

Based on what was discussed in the introduction, what types of energy will you be using? For each type, explain how you know you will be using it.

Question 4:

What type of energy/energies do you have at the initial point? What type of energy/energies do you have at the final point? Discuss.

- A) Open the logger pro file Velocity accompanying this lab.
- B) Make a table in your lab report like **Table 3**.

Table 3 – Part 3 Data

x_I	
x_F	
x	
v_1	
v_2	
v_3	
v_{avg}	

- C) After making sure that the spring is *not* compressed, measure the uncompressed length of the pillar x_I . See [Figure 5](#). Place this value in the table.

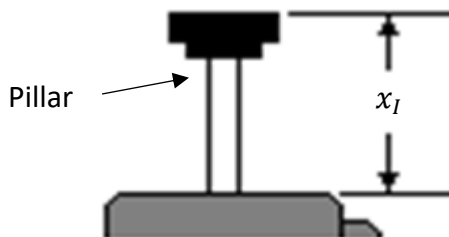

Figure 5 – Compression of Pillar

- D) There are three launch positions for the spring in the cart. Slowly push in the pillar until it locks into the SECOND position. If you are unsure about this then grab your TA for assistance.
- E) Measure the new compressed length of the pillar from the front of the cart and record it as x_F .
- F) Calculate the compression distance $x = x_I - x_F$ and add it to the table.
- G) With the launcher armed, place the cart on the track against the black stopper with the signal blocker facing the Motion Sensor.
- H) You are going to use the metal rod as a way of launching the cart.
- The cart doesn't have to go very far for this measurement, you can stop it after about 20cm and still get the velocity right after the launch.
 - There is a little button on the cart that, when pushed, will launch the cart. See [Figure 2](#). Using the rod in a flicking motion (yes, like a wand), tap the button.

- c. Practice launching the cart so that the cart launches with as little interference as possible from your tap and you are ready to catch it.
- I) One group member prepare to stop and catch the cart after a short distance. It only has to go 20 cm or so to get the max velocity.
 - J) Press collect on the logger pro file
 - K) Launch the cart by tapping the button.
 - L) Catch the cart...
 - M) Click your velocity graph then click the Statistics button.
 - N) Record the MAX value from the statistics as your velocity 1 in Table 1.
 - O) Repeat this measurement procedure two more times so you have three measurements, then average them to get v_{avg} for the table.
 - P) Using one of the digital scales in the lab, measure the mass of your cart with the signal blocker attached. Record this value.
 - Q) So, you are finally ready to deal with the energy part of this section. You might want to go back and reread your answer to **Question 4**.
 - R) Calculate the initial and final total energies for the launch.
 - a. HINT: Remember ... when dealing with the launch the *initial point* will be right before the cart is launched and the *final point* will be right after the cart is launched and the spring is not compressed anymore.
 - b. Also, you will be using the spring constant that you calculated from **Part 2**.
 - S) Calculate a percent difference. If you get a percent difference that is greater than 25% then check with your instructor.

What You Need To Turn In:

On a separate sheet of paper from this lab manual answer all of the questions, including all of the tables that you are asked to draw.