

# Lab 9: Ballistic Pendulum

Experiment for Physics 225 Lab at CSU Fullerton.

## What You Need to Know

### Introduction:

The ballistic pendulum is a pendulum with a device on the bottom end that “catches” a projectile from some type of launcher, and then converts the kinetic energy transferred to the catcher at the bottom of the swing, to gravitational potential energy as it swings up to a maximum height. Since the collision is inelastic, not all of the kinetic energy of the projectile before the collision actually gets transferred to the catcher plus projectile after the collision. By measuring the maximum vertical height that the projectile plus catcher swing up to, one can apply energy and momentum conservation to determine the initial velocity of the projectile as it leaves the launcher. The projectile could be a golf ball, baseball, tennis ball, soccer ball, paint ball, arrow, rock, bullet, cannon ball, steel ball bearing (as in this lab), or other object that one would like to know the speed of without having to measure its time of passage over a fixed distance. Knowing the launch velocity of a projectile enables one to calculate its kinetic energy, and its range with a simple formula, assuming the effects of air resistance are negligible.

The ballistic pendulum was invented in 1742 by English mathematician Benjamin Robins (1707–1751), and published in his book *New Principles of Gunnery*, which revolutionized the science of ballistics, as it provided the first way to accurately measure the velocity of a bullet. Other contemporaries used his method to determine the velocity of cannon balls of from 1-3 lbs.<sup>1</sup>

[Figure 1](#) shows a schematic idealization of a ballistic pendulum. As can be seen from the [Figure 1](#), there are 3 phases of the motion that allow determination of the initial velocity of the projectile immediately after its launch,  $v_0$ . The three phases are 1.) after the projectile launch and before the collision (left), 2.) immediately after the collision and before the catcher with projectile moves appreciably (center), and 3.) after the collision at the top of the pendulum swing (right).

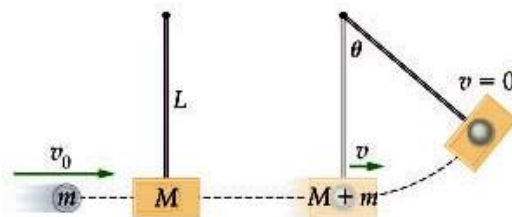

Figure 1 - Simple single rod ballistic pendulum schematic showing the 3 phases of the motion.

---

<sup>1</sup> [https://en.wikipedia.org/wiki/Ballistic\\_pendulum](https://en.wikipedia.org/wiki/Ballistic_pendulum) accessed 2/13/2019.

## Summary:

Today's experiment has two major parts:

1. In the first part you will determine the initial velocity  $v_0$  of a steel ball immediately after it leaves a spring loaded launcher.

This will be done by firing the projectile at the catcher and measuring the maximum horizontal distance  $\Delta x$  that the catcher plus steel ball is displaced from the bottom to the top of its swing. The procedure will be repeated at least 6 times to get a good average, since there will be some variation in the launch velocity from shot to shot. Momentum conservation during the collision and energy conservation after the collision will be applied to determine a formula for the initial velocity  $v_0$ . It will be necessary to measure the length  $l$  of the center to center distance between the pivot points on the swing arms, the mass of the steel ball  $m$ , and the mass of the catcher  $M$ . The mass of an individual swing arm  $m_a$ , should also be measured and recorded, although it is designed to be much smaller than the mass of the ball and catcher.

2. In the second part of the experiment, you will use the value of  $v_0$  determined in the first part above, combined with a careful measurement of the height of the bottom of the steel ball above the floor (when mounted on the launcher rod)  $H$ , to predict the horizontal distance  $D$  from the vertical centerline of the steel ball to where it hits the floor (see [Figure 7](#)).

A piece of fine cell graph paper will be taped to the floor (or rubber pad if available) with a line drawn on the paper labeled with the predicted distance  $D$ . Carbon paper oriented with the carbon face down will be placed on top of the paper, so that when the launched ball strikes the carbon paper on the floor, it will leave a black impression mark on the graph paper where it landed. 6 launches of the steel ball onto the paper taped to the floor should be made. The mean of the actual experimental distances (determined by measuring the distance from the predicted reference line to the black carbon marks on the paper) and their standard deviation will be determined and compared to the theoretical predicted distance.

*The graph paper with the carbon impressions and labeled reference distance on it should be turned in with the lab report, as that is primary data (if your instructor requires electronic submission of the lab report, take a good quality photo of your paper with the carbon impression and paste that in your Word document). A single lab report with your measurements, sample calculations, answers to questions, and short conclusion should be turned in for each station. Be sure to show sample calculations with the data from one of your trials for both parts of the experiment.*

## What You Need to Do

### Part 1: Determining the initial launch velocity $v_0$ of the projectile

#### *Theoretical Analysis for Determination of $v_0$ .*

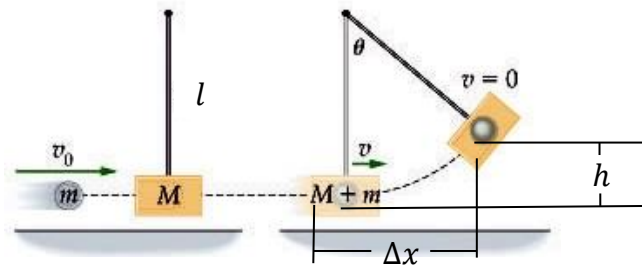

Figure 2 – multistage problem for ballistic pendulum

- A) The ballistic pendulum setup you'll be using is shown in [Figure 2](#). Start by analyzing it to find the initial velocity of the ball  $v_0$  in question 1.

#### **Question 1:**

Show the steps in deriving the following equation for the initial velocity of the ball  $v_0$  in relation to the height that the ball swings up to,  $h$ , the mass of the ball  $m$ , the mass of the catcher  $M$ , and the local gravitational constant  $g$ .

$$v_0 = \frac{(m + M)}{m} \sqrt{2gh}$$

*For details or assistance in deriving this equation see Appendix A, or your instructor may wish to walk you through it.*

- B) To assist in this experiment an excel spreadsheet is provided that utilizes the above equation with values that you will measure. Open the Ballistic Pendulum Calculations spreadsheet and check out the equations in cells G15-G20 and H15-H20 to verify you understand it's the equation found in question 1.
- C) Note that the height  $h$  is a bit tricky to measure, but can be found from the horizontal motion of the arm, which is derived in Appendix B to be approximately

$$h \cong \frac{\Delta x^2}{2l}$$

where  $\Delta x$  is the horizontal displacement of the catcher, and  $l$  is the length of the swing arms. Locate cells E15-E20 and verify you understand its utilizing this equation.

### Experimental procedure for determination of $v_0$

Now you'll find  $v_0$  experimentally by taking the data needed for the equation in question 1.

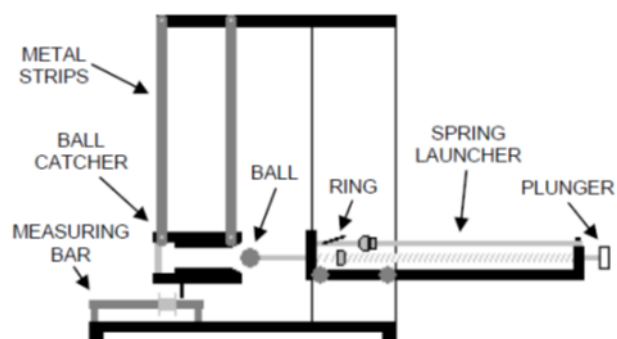
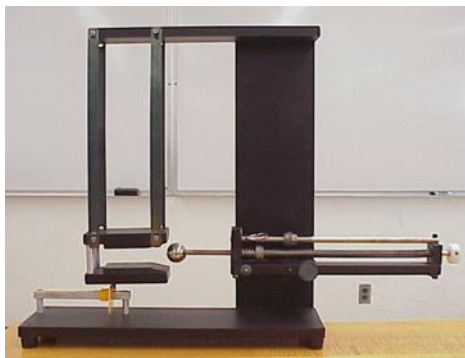
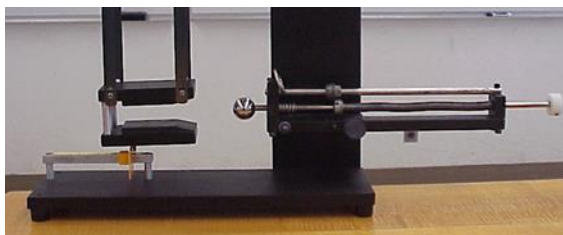

Figure 3 - (left) Photo of ballistic pendulum apparatus used in this lab. The slider is shown directly underneath the catcher. (right) Schematic diagram of ballistic pendulum.

D) Prepare to Launch the ball.

- a. Using the white plunger knob on the end of the launcher, pull it back so that it compresses the spring and holds it there, as shown in [Figure 4](#).

Figure 4 - Photo of spring launcher in the cocked position with steel ball mounted on the end. Pull the white knob to the right to cock the spring. Pulling up the ring on the left of the top rod launches the projectile.



- b. The steel ball has a hole thru it that allows it to mount on the end of the launcher rod. Place the steel ball on the launching rod and make sure the ball is put all the way onto the rod so that it contacts the larger diameter portion of the rod.

**Note:** It must be in this position when the launching ring is pulled up to avoid large errors.

- c. Use a pencil, pen, or lightweight ruler to gently nudge the slider so that it contacts the small vertical rod underneath the catcher and record the initial reading  $x_i$  of one end of the slider which is on the yellow measuring tape attached to the top of the measuring bar, as shown in [Figure 5](#).

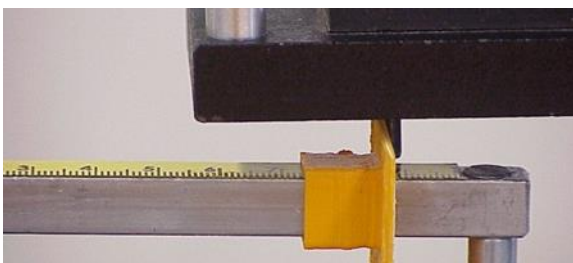

Figure 5 - Close up of catcher, slider, and measuring bar. Take measurements from the end of the slider that is farthest from the rod on the bottom of the catcher.  $x_i = 7.3\text{cm}$  shown.

- d. Make sure you measure the initial position of the slider to an accuracy of less than 1mm (the scale readings are only 1mm apart, so estimate to the nearest 0.5mm).
- e. Enter this value in the labeled and highlighted column in the ballistic pendulum spreadsheet provided.
- E) Launch the projectile
- Before launching, insure that the ball is all the way back on the launching rod and that the short rod on the bottom of the catcher is in contact with the slider, as shown in [Figure 5](#). *The measurements of the initial and final positions of the slider are the largest sources of error in the experiment, and it is essential that care be taken in determining them.*
  - Hold the apparatus down firmly with one hand to keep it from moving while the launching ring is pulled straight up, in order to prevent the catcher from swinging due to pulling on the launching ring.
  - To launch pull straight up on the steel ring, taking care not to disturb the catcher or move the slider during the process.
- F) Record the final position  $x_f$  of the slider on the same end you measured the initial position to the nearest 0.5mm. Enter this value in the labeled and highlighted column of the ballistic pendulum spreadsheet, shown in [Figure 6](#).

Ballistic Pendulum											
Enter your numbers in highlighted cells											
Measured Apparatus Data											
Catcher	Steel Ball	Swing Arm	Center to center	Swing Arm	Height of ball	Local gravity					
Mass	Mass	Mass	Length		H (cm)	g (m/s <sup>2</sup> )					
M (g)	m (g)	m <sub>a</sub> (g)	l (cm)		103.4	+/- 2mm	(9.8067 std)	Ref. Mark			
1084	63.2	6.5	24.8		(meas. from bottom of ball)			Distance			
											D <sub>r</sub> (cm)
											131
Determination of maximum height $h$ , initial velocity $v_0$ , velocity after collision $V$ , fraction of K.E. lost, Horizontal Range $D$											
Trial	Initial slider	Final slider	Horizontal	Vertical	neglected	Catcher+ball	Projectile	Fractional	Predicted	Measured	Measured
Number	$x_i$ (cm)	$x_f$ (cm)	$\Delta x =  x_f - x_i $ (cm)	$h$ (cm)	$h/2l$	$V$ (m/s)	$v_0$ (m/s)	%	$D$ (m)	$\Delta D_m$ (cm)	$D_m$ (m)
1	7.30	4.80	2.500	0.1260	2.540E-03	0.1572	2.8536	94.4909	1.3104	15.200	1.4620
2	7.30	4.80	2.500	0.1260	2.540E-03	0.1572	2.8536	94.4909	1.3104	14.500	1.4550
3	7.30	4.70	2.600	0.1363	2.748E-03	0.1635	2.9678	94.4909	1.3628	13.400	1.4440
4	7.30	4.65	2.650	0.1416	2.854E-03	0.1666	3.0248	94.4909	1.3890	17.400	1.4840
5	7.30	4.70	2.600	0.1363	2.748E-03	0.1635	2.9678	94.4909	1.3628	16.500	1.4750
6	7.30	4.80	2.500	0.1260	2.540E-03	0.1572	2.8536	94.4909	1.3104	15.600	1.4660
Mean			2.5583	0.1320	0.0027	0.1609	2.9202	94.4909	1.3410	15.4333	1.4643
Standard Deviation			0.0665	0.0069	0.0001	0.0042	0.0759	0.0000	0.0348	1.4208	0.0142
										% error =	9.20

Figure 6 - Ballistic pendulum spreadsheet calculations based on sample data. Enter your numbers in the highlighted cells only, which will be empty when you open the spreadsheet.

- G) Repeat the previous steps 5 more times so that you have 6 total “good” values of the horizontal displacement  $\Delta x = |x_f - x_i|$ . The values should not deviate by more than 5-10% from the average of all 6 values (hopefully less). You can check this by entering the values in the spreadsheet, which calculates the mean and standard deviation of the 6 trials at the bottom of each column.

- H) Measure the center to center distance between the pivot points of any one metal strip, which is the swing arm length  $l$ . Enter the swing arm length  $l$  into the labeled cell in the spreadsheet.
- This can be done when the swing arms are mounted on the catcher, *taking care to note where the center of the pivoting locations are. (Note that  $l$  is NOT the end to end length of the swing arms!).*
- I) Use a scale in lab to measure the masses of the steel ball  $m$ , the catcher  $M$ , and one of the swing arms  $m_a$
- Carefully remove the ball catcher apparatus from the swing arms.
  - Carefully** remove the metal strip swing arms from the ball catcher and apparatus, supporting it with one hand underneath while taking them off the catcher. *The metal strip swing arms can bend and break easily, so be careful.*
  - LEAVE THE SWING ARMS OFF THE CATCHER AND APPARATUS FOR NOW SINCE THEY MUST BE OUT OF THE WAY FOR THE NEXT PART OF THE EXPERIMENT.
- J) Observe that the calculations for the initial projectile velocity  $v_0$  are performed in the provided ballistic pendulum spreadsheet once you enter all 6 values of the initial and final positions of the slider, the length of the slider arms, and the masses of the catcher, projectile and swing arm.
- The spreadsheet calculates all the important relevant quantities, the swing height  $h$ , the error term  $h/2l$ , the catcher plus projectile velocity  $V$  after the collision, the fractional amount of kinetic energy lost due to the inelastic collision, but most importantly, the mean and standard deviation of the initial velocity of the projectile  $v_0$ . The initial projectile launch velocity is the only input from this section to the next part of the experiment on determining the projectile range.
- K) Note the initial projectile launch velocity that is calculated from the equations in the excel sheet. It will be used in the next section.

## Part 2: Determining the horizontal range $D$ of the projectile from the initial velocity $v_0$ .

If the catcher weren't there, how far horizontally would the ball go before hitting the ground?

### *Theoretical Analysis for Determination of $D$ , the range of the projectile.*

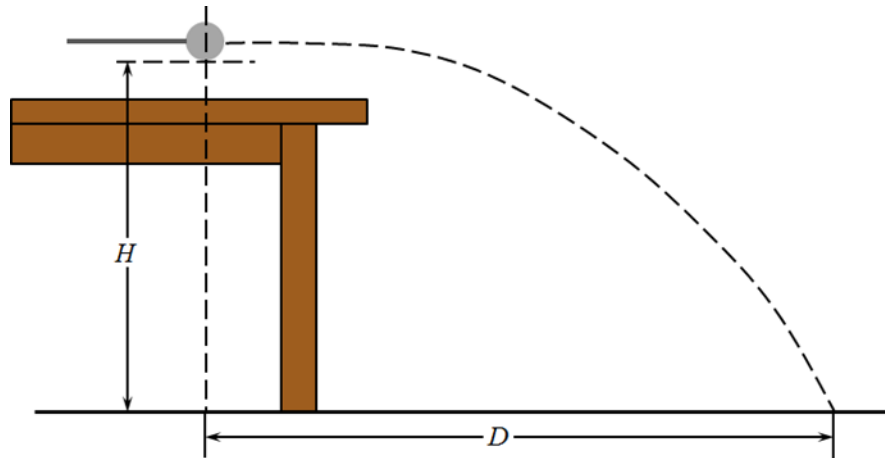

Figure 7 – Diagram of the ball launch off the table.

#### **Question 2:**

Show the steps in deriving the following equation for the distance the ball will travel  $D$ , in relation to the initial velocity of the ball  $v_0$ , and the height from the bottom of the ball to the floor  $H$ , and the local gravitational constant  $g$ .

$$D = v_0 \sqrt{2H/g}$$

See Appendix C for assistance in this calculation and explanation of what the height  $H$  is.

- A) Again this is calculated for you in the spreadsheet based off your measurements in part 1. Take a look at cells J15-J20 to verify this equation is in use.

### ***Experimental procedure for Measuring $D$ , the range of the projectile***

Now take experimental measurements to verify the above theory for calculating  $D$ . We'll utilize the prediction for  $D$  in our measurements.

- A) Take an accurate measurement of the bottom of the steel ball to the floor.
- a. This should be done to an accuracy of no worse than 0.5 cm.
  - b. Use a 2 meter stick suspended vertically and plastic ruler to measure the distance to the floor from the bottom of the steel ball when it is mounted on

the launcher, with the launcher not cocked (this is the position that the ball is released from with horizontal velocity  $v_0$  as shown in [Figure 8](#)).

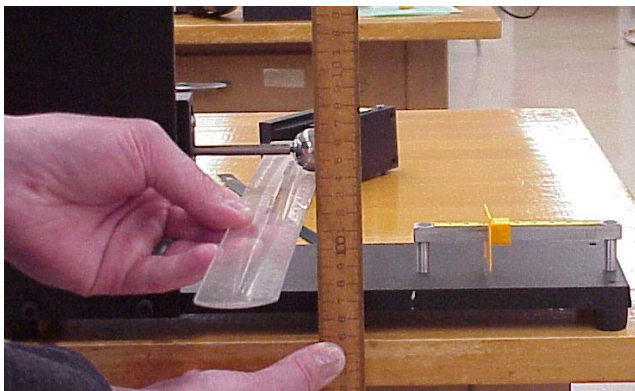

Figure 8 - Measuring method to determine  $H$  using a 2 meter stick and small ruler placed under the steel ball and held horizontally. The other end of the vertical 2 meter stick is on the ground.

- c. Put a piece of masking tape on the floor with the edge against the back of the 2 meter stick where it contacts the floor.
  - d. Enter the value of  $H$  that you just measured in the labeled cell of the ballistic pendulum spreadsheet. The spreadsheet will now calculate the predicted value of  $D$  for each trial and the average and standard deviation of these values.
- B) Now locate the average predicted value of  $D$  from the spreadsheet calculation.
- a. Use a 2 meter stick to measure from the tape on the floor in part A) to the predicted distance  $D$  and put another piece of masking tape on the floor with its edge where the predicted distance  $D$  is.



Figure 9 - Setup showing how to measure the horizontal reference distance  $D_r$  using masking tape on the floor. Fine cell graph paper is taped on the rubber mat in a cardboard box lid. Carbon paper placed face down on the graph paper leaves black impression marks where the steel ball lands.



- b. The distance between the 2 nearest edges of the pieces of tape on the floor should be the average predicted distance  $D$ , (see [Figure 9](#)). This is called the reference mark distance  $D_r$  in the spreadsheet.
  - c. Take a piece of mm cell graph paper and draw a horizontal line on it near the bottom of the paper when the paper is oriented with the long side vertical. Label this line with the average predicted distance on it.
  - d. Match up the line on the graph paper with the line on the tape on the floor, and tape the graph paper down, face up, to the rubber sound deadening mat in the box. That way the graph paper will have a calibrated reference line on it at the predicted distance  $D$  away. (see [Figure 9](#))
- C) Take one or two trial shots with just the graph paper to make sure that the launching apparatus is lined up and that the ball lands within about 10-15 cm of the predicted line and not too far off the center line of the short edge of the graph paper. If not, double check your measurements in steps A),B) and move the graph paper as necessary. Be sure to label a reference line on the graph paper where it lines up with the reference distance  $D_r$ .
- D) Lay carbon paper on top of the graph paper, black carbon face down so that when the steel ball lands on the carbon paper, it will leave a black impression mark on the graph paper.

***DO NOT TAPE THE CARBON PAPER, the graph paper should be fixed down but the carbon paper can move freely and still do it's job.***

- E) Now make 6 shots with the carbon paper face down on top of the graph paper.
- a. After each shot lift the carbon paper and label the mark with the corresponding trial number as shown in [Figure 10](#).
- F) Lift the carbon paper to ensure that the steel ball left at least 6 good marks on the graph paper.
- G) When you are done with launching the steel ball onto the floor, carefully remount the catcher and swing arms onto the apparatus
- H) Take your graph paper off of the box and measure the distances of the black carbon round impressions from the predicted value of  $D$  line that was drawn on the paper in part iii.).
- a. See the example in [Figure 10](#).
  - b. So that you do not make a mistake, for each impression enter the distance from the predicted reference line to the darkest point of the black impression, call them  $\Delta D_m$ .
  - c. Make this distance negative if it is less than  $D$  and positive if it is farther than  $D$ . Enter the actual reference distance  $D_r$  labeled on the graph paper in the

cell on your spreadsheet and these 6 values of  $\Delta D_m$  (in cm!) in the labeled column of the spreadsheet.

- d. The spreadsheet will calculate the corresponding measured value of  $D_m^2$  for each trial (in meters), the mean and standard deviation of the 6 measured values and the percent error<sup>3</sup> between the average experimental and average theoretical values.

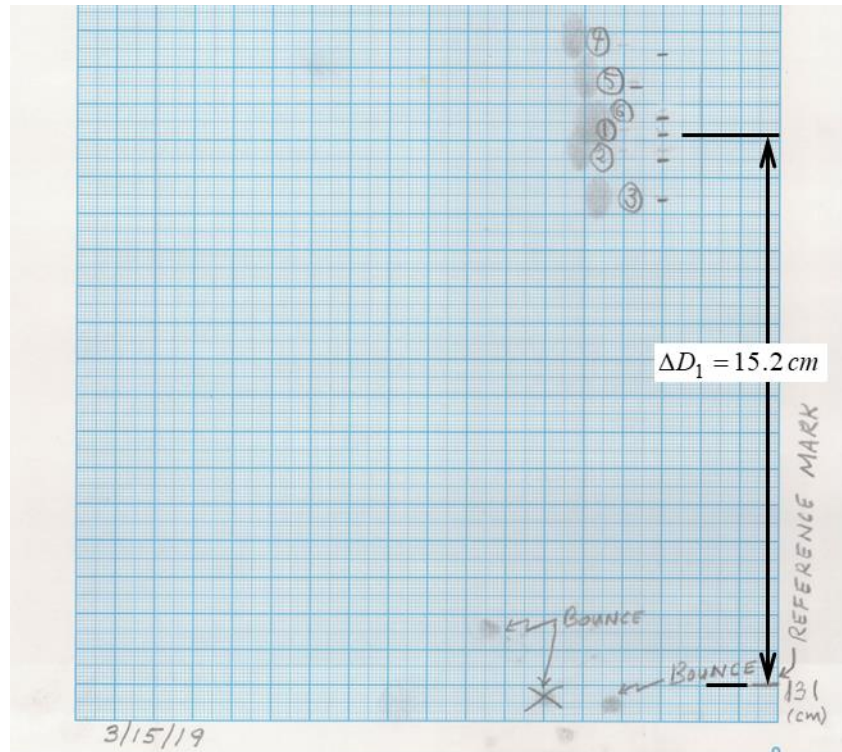

Figure 10 - Steel ball impact data showing reference mark labeling and example of distance from reference mark to carbon paper black impression. Enter these numbers for each trial shot in the spreadsheet column labeled  $\Delta D_m$ , example  $\Delta D_1$  shown.  $D_r = 131$  cm in this example.

- I) Prepare to submit your excel table to your instructor.
- If using word copy the table and paste it as an image (through the right click menu). DO NOT just use copy from Excel and paste into Word, the spreadsheet formatting will be a mess in the word document.
- J) Prepare to submit your graph paper with measurements.
- Since this is primary data, make sure to include your graph paper with the labeled average predicted line, and the average measured line drawn on it in your lab report.

$$^2 D_m = (D_r + \Delta D_m)$$

$$^3 \% \text{ Error} = \frac{|\text{Experimental} - \text{Theoretical}|}{|\text{Theoretical}|} \times 100.$$

- b. If your instructor requires electronic submission of your lab report, include a good quality photo of the graph paper with the black impressions from the impact of the steel ball on it pasted in your Word document. (use your phone camera).
- K) Take a few minutes to examine all the columns and calculations on the spreadsheet and understand what each calculation is doing.
- a. *You should take one row of the spreadsheet and perform sample calculations of each quantity in that row in order to make sure that you understand how to perform the calculations and that the spreadsheet calculations are correct.*
  - b. Refer to eqns. 10-23 as needed to perform the calculations.
  - c. Include the sample calculations in your report in a section labeled Sample Calculations.
- L) The results of your experiment can be summarized by the average predicted value of  $D$  plus or minus 2 standard deviations<sup>4</sup>, and the average measured value of  $D_m$  plus or minus 2 standard deviations.
- M) Calculate the percent error of the two values in your conclusion or summary of the experiment.
- N) Please make sure the lab is now setup as it was when you entered the room before leaving.

**Question 3:**

Do the predicted and measured average values overlap within the error uncertainty values? Answer with specific examples from your data.

---

<sup>4</sup> It has become more common to report error uncertainty values corresponding to 2 standard deviations, instead of 1 standard deviation as done previously.

## Analysis Questions

Answer the following questions to your instructors discretion based on available remaining time and what your instructor would like you to focus on.

*These could also be answered at home in preparation for the lab.*

### **Question 4:**

What is being ignored in applying momentum conservation to the collision between the projectile and catcher? (hint; what is the condition for momentum to be conserved?) Is this condition satisfied and why or why not?

### **Question 5:**

What if any errors are introduced by assuming the momentum during the collision is conserved?

### **Question 6:**

Consider the swing arms in this application:

- What is the effect of the movement of the swing arms? How should this be accounted for? (they contribute differently to the momentum of the catcher, its kinetic energy, and its gravitational potential energy).
- Does including the effects of the swing arms increase or decrease the predicted distance?

### **Question 7:**

What are the effects of the friction, momentum, and kinetic energy of the slider?

### **Question 8:**

What are the effects of friction in the 8 swing arm pivots due to the rotation?

Optional additional consideration:

### **Question 9\*:**

- Can you find a rough estimate for the collision time assuming the catcher does not move more than 1 mm during the collision?
- How large is the correction term and what is the size of the error due to making the approximation of neglecting  $h/2l$  in eqn. 22?

## Appendix A:

### *Theory for determination of $v_0$ .*

In the simple single rod ballistic pendulum of figure 1, the catcher with ball rotates about the top pivot point, thus the initial kinetic energy involves the moment of inertia of the catcher (with projectile) and rod about the pivot point. To avoid this complication and eliminate the rotation of the catcher with projectile, parallelogram linkage is used, as shown in [Figure 11](#). The modification of the ballistic pendulum using parallelogram linkage is called Ackley's ballistic pendulum and was first described in 1962<sup>1</sup>. As can be seen from [Figure 11](#), the parallelogram linkage prevents the catcher from rotating (like a glider on a swing set), thus eliminating angular rotation and catcher moment of inertia effects that are not accounted for in the simple formulation. The ballistic pendulum used in this lab uses parallelogram linkage, as shown in [Figure 11](#).

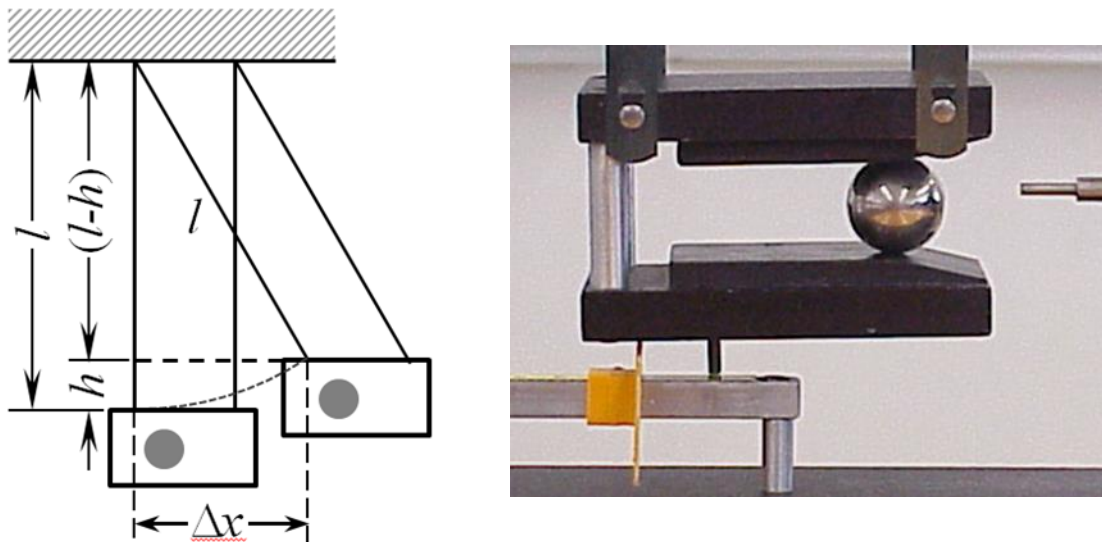

Figure 11 - (Left) Schematic diagram of ballistic pendulum with parallelogram linkage. Due to the collision of the projectile with the catcher, the catcher with steel ball moves a horizontal distance  $\Delta x$  and up a distance  $h$ . (Right) Photo of catcher showing the location of the steel ball when caught and the yellow slider moved by the rod underneath the catcher during its swing.

Newton's 2<sup>nd</sup> law applied to a system of particles can be written as (consult your textbook or instructor for the derivation of this form of Newton's second law)

$$\frac{d\vec{P}_{cm}}{dt} = \vec{F}_{net,ext} \quad (1.)$$

Where  $\vec{P}_{cm}$  is the momentum of the center of mass of the particles, and  $\vec{F}_{net,ext}$  is the net external force acting on the system of particles (i.e. the vector sum of the external forces acting on the system of particles). The internal forces between the particles sum to zero by Newton's 3<sup>rd</sup> law of action and reaction, so they do not have to be considered in the sum of the forces.

Equation 1 is a vector equation, so it applies to each vector component on the left and right hand sides of eqn 1. For the 2 dimensional motion considered here,

$$\frac{dP_{cm,x}}{dt} = F_{net,ext,x} \quad (2.)$$

$$\frac{dP_{cm,y}}{dt} = F_{net,ext,y} \quad (3.)$$

If the net external force is zero in the x direction,  $F_{net,ext,x} = 0$ , then from eqn. 2

$$\frac{dP_{cm,x}}{dt} = 0 \quad (4.)$$

Eqn. 4 then implies that

$$P_{cm,x} = \text{constant} \quad (5.)$$

or equivalently between an initial and final state when there is no net external x force acting,

$$P_{cm,x,initial} = P_{cm,x,final} \quad (6.)$$

Since the center of mass momentum  $\vec{P}_{cm}$  equals the total momentum  $\vec{P}_{tot}$  of the system of particles, eqn. 6 can be rewritten as

$$P_{tot,x,initial} = P_{tot,x,final} \quad (7.)$$

Equation 7 is the statement of momentum conservation along the x direction when there is no net external force acting along that direction during the motion between the initial and final states chosen.

Similarly, for the case when there is no net external force in the y direction,  $F_{net,ext,y} = 0$ , the same steps and reasoning shows that the total momentum in the y direction is also conserved

$$P_{tot,y,initial} = P_{tot,y,final} \quad (8.)$$

For the case at hand, we have two objects in motion, the projectile and the catcher. Initially the catcher is not moving or accelerating, so the sum of the external forces acting on the catcher is initially zero. During the catching process, it is assumed that it takes place so quickly that the motion of the catcher is negligible, so that the net external forces in both the x and y directions remain zero during the collision, and we can apply momentum conservation along the x direction (the y direction momentum is initially zero and remains zero during the collision).

Before the collision, only the projectile of mass  $m$  is moving horizontally with velocity  $v_0$ . Immediately after the collision, both the projectile and catcher of mass  $M$  are moving horizontally with the same speed  $V$ . This situation is called a completely inelastic collision, or sometimes a perfectly inelastic collision. Equation 7 can be written for this situation as

$$P_{tot,x,initial} = mv_0 + 0 = mV + MV = P_{tot,x,final} \quad (9.)$$

Solving eqn. 9 for the initial projectile velocity  $v_0$  in terms of the velocity  $V$  of the catcher plus projectile immediately after the collision.

$$v_0 = \frac{(m+M)}{m}V \quad (10.)$$

Equation 10 reveals that for a light projectile where  $M \gg m$ , the initial velocity  $v_0$  is much, much larger than the velocity of the catcher  $V$ , after the collision.

The initial kinetic energy before the collision  $K_i$  is

$$K_i = \frac{1}{2}mv_0^2 \quad (11.)$$

The final kinetic energy immediately after the collision  $K_f$  is

$$K_f = \frac{1}{2}(m+M)V^2 \quad (12.)$$

Substituting eqn. 10 into eqn. 11 yields

$$K_i = \frac{(m+M)^2}{2m}V^2 \quad (13.)$$

The fractional loss of kinetic energy  $F$  can be found using eqns. 12 and 13 as

$$F = \frac{K_i - K_f}{K_i} = \left(1 - \frac{K_f}{K_i}\right) = \frac{M}{(m+M)} \quad (14.)$$

For the case of a light projectile, where again  $M \gg m$ , the fraction of kinetic energy lost approaches one, corresponding to a loss of all the kinetic energy.

The kinetic energy immediately after the collision at the bottom of the swing is completely converted to gravitational potential energy change at the top of the swing of the pendulum (assuming friction is negligible). The conservation of mechanical energy for this process can be written as,

$$\Delta K + \Delta U = 0 = \left(0 - \frac{1}{2}(m+M)V^2\right) + (m+M)gh \quad (15.)$$

Where  $h$  is the vertical distance the center of mass of the catcher plus projectile rises up at the highest point of its swing. Solving eqn. 15 for  $V$  yields,

$$V = \sqrt{2gh} \quad (16.)$$

Substituting eqn. 16 into eqn. 10 yields the simple formula for the initial velocity of the projectile  $v_0$  in terms of the maximum height  $h$  of the pendulum swing shown in [Figure 11](#)

$$v_0 = \frac{(m+M)}{m}\sqrt{2gh} \quad (17.)$$

So in principle all one has to do is measure the masses of the projectile and catcher, and the height of the pendulum swing, and then use eqn. 17 to calculate the initial projectile velocity  $v_0$ .

The problem with this method to determine  $v_0$  is that the actual height  $h$  for our apparatus is very small, less than 1 mm. Therefore the determination of an accurate value for  $h$  must use an indirect method. From the diagram of [Figure 11](#), we can see that for small angles of swing, the horizontal distance moved,  $\Delta x$ , is much greater than the vertical distance moved,  $h$ .



## Appendix B: Determination of the height of the swing $h$ from the horizontal displacement $\Delta x$

Referring to [Figure 11](#) and using the Pythagorean theorem yields the relationship between the horizontal distance moved  $\Delta x$ , (which is what is actually measured via the slide and a measuring tape on the slider bar), and the maximum height  $h$  that the pendulum plus projectile rises due to the momentum of the catcher plus projectile after the collision.

$$(l - h)^2 + \Delta x^2 = l^2 \quad (18.)$$

Expanding out the left hand side of eqn. 18,

$$l^2 - 2lh + h^2 + \Delta x^2 = l^2 \quad (19.)$$

and simplifying

$$-2lh + h^2 + \Delta x^2 = 0 \quad (20.)$$

Equation 20 is a quadratic equation for the height  $h$  in terms of the horizontal displacement  $\Delta x$  and  $l$ , the length of the pendulum arms between the pivot points. Equation. 20 could be solved exactly for  $h$  using the quadratic formula, however, that complication is not necessary. It is simpler to use the fact that for the apparatus at hand, the displacement  $h$  is much, much smaller than the pendulum arm length  $l$ , which allows us to obtain a very accurate and simple approximate formula for  $h$ . Equation 20 is rewritten to emphasize this fact as

$$h(2l - h) = \Delta x^2 \quad (21.)$$

Dividing both sides by  $2l$  yields

$$h \left( 1 - \frac{h}{2l} \right) = \frac{\Delta x^2}{2l} \quad (22.)$$

For our lab apparatus, the distance  $h$  is very much less than  $l$ , as we will see, the ratio  $h/2l$  is less than about 3/1000, leading to a correction term in parenthesis that is less than than 0.3% (i.e. 3 parts in a 1000). Neglecting the small term  $h/2l$  in eqn. 22 yields the simple, approximate formula for the height  $h$ .

$$h \cong \frac{\Delta x^2}{2l} \quad (23.)$$

Measurement of the horizontal displacement of the slider  $\Delta x$ , the length of the swing arms between the pivot points  $l$ , combined with eqn. 23 allows determination of the height  $h$ . Substitution of this value of  $h$  into eqn. 17 gives the initial velocity  $v_0$ .

## Appendix C: Theory for determination of $D$

Since the launch is horizontal, the projectile travels a distance  $D = v_0 t$  horizontally in time  $t$ , where  $v_0$  is the initial horizontal launch velocity. For the time required to hit the floor, since the launch is horizontal there is no initial vertical velocity, and the projectile falls a distance  $H = gt^2/2$  in time  $t$ . Solving for the time  $t$  in terms of  $H$  and substituting in the equation for  $D$  yields the equation for the projectile range  $D$  when launched horizontally from a height  $H$ ,

$$D = v_0 \sqrt{2H/g} \quad (24.)$$

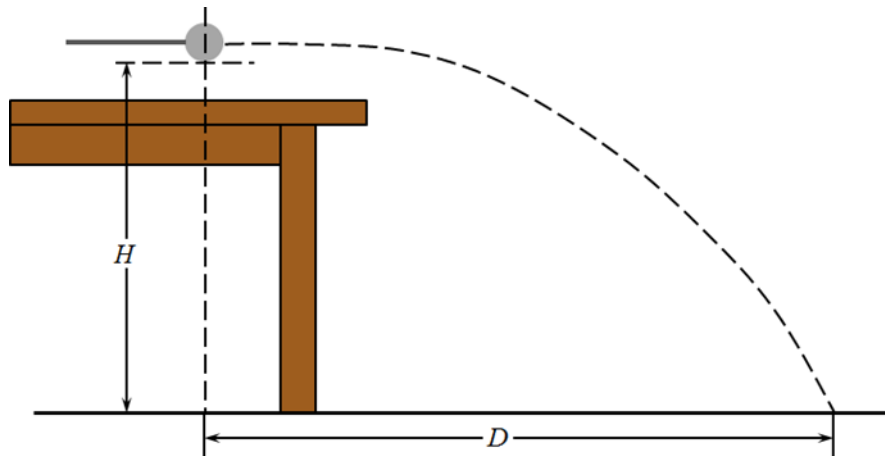

*Figure 12 - Horizontal and vertical projectile travel distances  $D$  and  $H$  defined. The ball on the launcher rod is in the uncocked position. A suspended 2 meter stick with the back edge passing thru the centerline of the ball and just touching the floor allows one to locate the line on the floor passing thru the vertical center plane of the projectile.*

Referring to [Figure 12](#), the vertical distance  $H$  is the distance from the *bottom* of the steel ball when mounted on the launcher to the floor (since the bottom of the ball touches the floor). Also, the horizontal distance  $D$  is measured from the vertical center plane of the steel ball, since this is the plane where the bottom of the ball touches the ground. From eqn. 24, one only need carefully measure  $H$  and have a value of  $v_0$  from part 1 to predict the range  $D$  of the projectile.