

Series and Parallel Resistors

What You Need To Know:

The Physics Last week you examined how the current and voltage of a resistor are related. This week you are going to examine how the current and voltage of different combinations of resistors are related.

There are two ways in which resistors can be hooked up in a circuit. They can be attached either in *series* or in *parallel*. Let's look at series resistors first. If there are no branch points between two consecutive resistors, then they are in series. In **Figure 1a**, resistors R_1 and R_2 are in series. In **Figure 1b**, R_1 and R_2 are not in series because there is a branch point [that goes to resistor R_3] in-between R_1 and R_2 .



FIGURE 1 -
Circuit diagrams. (a) R_1 and R_2 are in series.
(b) R_1 and R_2 are not in series.

To aid in analyzing a circuit, groups of resistors can be combined together to form an *equivalent* resistor. Series resistors can simply be added together as in **Figure 1**. You can add together any number of series resistors.

Let's say that you have current flowing through the circuit from left to right in **Figure 1a**. As the current leaves R_1 , there is nowhere else for it to flow through but R_2 . So, we can say that any series resistors have the same current. In **Figure 1b**, however, we cannot say that the current is the same in R_1 and R_2 because not all of the current will flow through R_2 , some of it will flow down through R_3 .

Now let's look at parallel resistors. If you begin at a branch point, like points A or B in **Figure 2**, and follow each branch, going through only ONE resistor for each branch, and then meet back at a common point, then you have parallel resistors. For example, in **Figure 2**, if you start at branch point A and follow each branch, which goes through only R_1 for one branch and only R_2 for the other, and then meet back at branch point B, we can then say that R_1 and R_2 are in parallel. Do not make the mistake that if they are physically **drawn** parallel then they are in parallel.

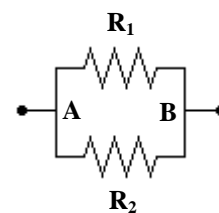

FIGURE 2 -
Circuit diagram.
 R_1 and R_2 are in parallel

Conversely, in **Figure 3**, R_1 and R_2 are no longer in parallel because there are now TWO resistors in the upper branch.

When adding parallel resistors together to form equivalent resistors you cannot simply add them together as with series resistors. Instead, you must add the parallel resistors together as reciprocals. See **Figure 4**. As with series resistors, you can add together any number of parallel resistors.

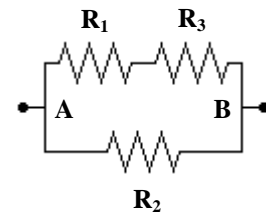

FIGURE 3 –
Circuit diagram.
 R_1 and R_2 are not in parallel.

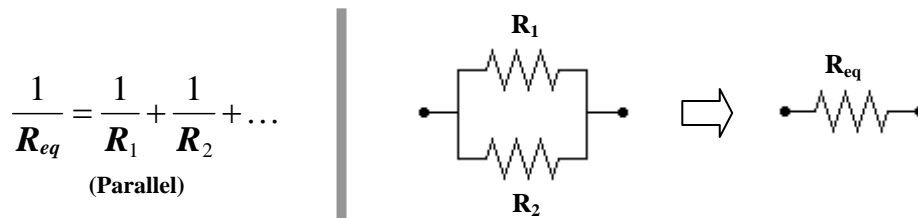
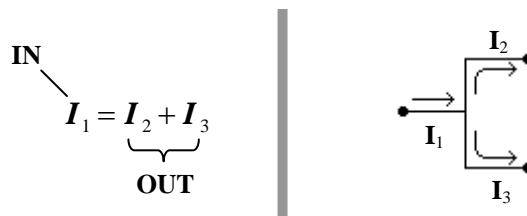

FIGURE 4 - Parallel Resistors

Let's say that you took the leads from a voltmeter and placed them in the upper two corners of the circuit in **Figure 2**. The voltmeter would read the voltage across R_1 . If you moved the leads down a little towards points A and B, would the voltage reading change? No, it would remain the same. As long as either lead doesn't cross an element, it won't change the reading. That means we could continue moving all the way down to the lower two corners and still get the same voltage reading, but that reading should be the voltage across R_2 . This leads to the idea that any resistors in parallel have the same voltage.

Kirchhoff's Laws There are two more ideas that will help you to analyze circuits. They are called Kirchhoff's Laws. The first law is called the *Branch Law* and the second law is called the *Loop Law*.

Branch Law - At any branch point, the sum of all the currents flowing into a branch must equal the sum of all the currents flowing out of the branch.



Loop Law - The sum of the gains in voltage and drops in voltage around any closed path of a circuit must be zero.

$$V_{batt} - V_1 - V_2 - V_3 = 0$$

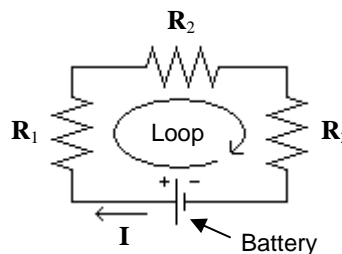

When applying the Loop Law, there are several details that you need to keep in mind. First, in order to determine if you have a gain or drop in voltage you must first decide in which direction the current is flowing through the circuit. We are defining that the Conventional Current is flowing out of the positive side of the battery and is flowing to the negative side. This is not actually what is happening. The real current, or the flow of electrons, is flowing the opposite way. [You can thank Benjamin Franklin for the confusing situation.] When writing the equation for a chosen voltage loop, you will get a voltage GAIN when you cross a RESISTOR in a direction OPPOSITE to that of the Conventional Current. [For the remainder of the lab, the Conventional Current will be referred to as just “current”.] You will also get a GAIN in voltage when crossing a BATTERY going from the negative side to the positive side. [You will get a DROP when crossing the other way.] You will get a voltage DROP when you go through a RESISTOR in a direction that is the SAME as the current. Also, it doesn’t matter where you begin your loop as long as it’s a complete loop and you do not retrace your path.

Summary There are four main ideas that enable you to analyze a circuit. In general, one of them will always help you. If not, then there are tons of “circuit tricks” out there to help you. Unfortunately, a lot of them only apply to specific situations. You will not have to worry about circuit tricks for this lab. This lab is designed to help you better understand how to apply the four main circuit ideas.

Four Main Circuit Ideas

- | | |
|---|---------------------|
| I. Series resistors have the same current. | III. The Branch Law |
| II. Parallel resistors have the same voltage. | IV. The Loop Law |

What You Need To Do:

The Setup There is no new equipment that you will be using this week. You should already be familiar with the power supply and the voltmeter. Your voltmeter should be set up in DCV. There will be several times during the lab in which you will want to change the setting on the voltmeter in order to get more significant figures in your voltage measurements. Your TA should discuss this. As far as the power supply goes, the MAX voltage will be +10 V and that will stay that way throughout the lab.

As you work your way through the lab, you will be filling out a VIR chart for each circuit. See **Figure 5**. The columns should always be V-I-R. These variables correspond to Ohm's Law, $V = IR$. The rows will always start with the battery's values. The remainder of the rows will consist of the resistors in your circuit. **Do not fill out the chart all at once.** Each section will ask you to do a specific calculation. You will need to show one sample calculation for each section as well as answer any questions. Show all calculations and answer all questions in the section that asks for them.

	V	I	R
Batt.			
R_G			
R_1			
R_2			
...			

FIGURE 5 - VIR Chart

The circuit board in front of you has three circuits on it. In **Part 1** of the lab you will be analyzing the very top circuit and then you will work your way down the board for the other parts of the lab.

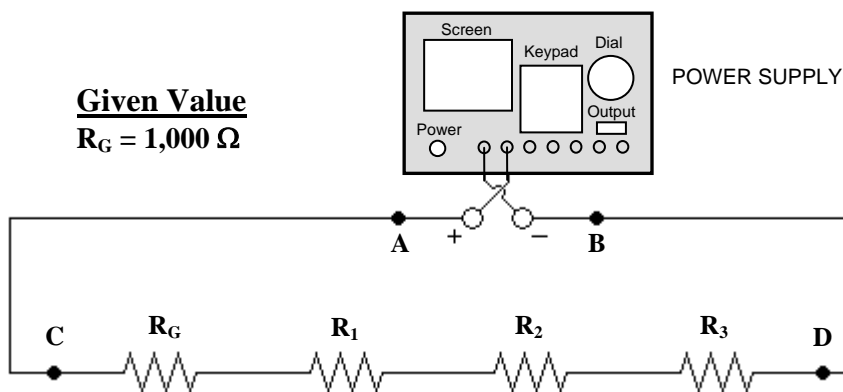

FIGURE 6 - Circuit diagram

Part 1 – Top Circuit The four resistors in this part of the lab are in series. See **Figure 6**. Any resistor value with a “G” as a subscript tells you the value is GIVEN. You will be using a voltmeter to measure the voltage across each of these resistors. The following describes a method for analyzing a circuit. The main goal of which is to calculate the total resistance of the circuit in two different ways.

Again, do not fill out the VIR chart all at once. Follow the directions.

A) Make a chart similar to **Figure 5** on the previous page for this first circuit.

B) Turn on the power supply. Push OUTPUT. Make sure it is set to +10 V. Place this value in your chart for the voltage of the battery.

C) Using the leads from the voltmeter, measure the voltage, V_G , across the resistor R_G . Make sure to set the voltmeter to give you as many digits as possible. Place this value in the VIR chart. You can also place the resistance value of R_G in the chart since it is given in **Figure 6**.

D) Calculate the current through R_G and put it in the chart.

Question 1 What is the current coming out of the battery? Explain why? Place this current value in the chart.

E) You can now calculate the total resistance of the circuit and place it in the chart under R in the Batt row. This is not the resistance of the battery. It can be thought of as the total resistance that the battery “sees” when looking out at the circuit. [More lingo.]

Question 2 What is the current through each of the other resistors? Explain why? Place all these current values in the chart.

F) Using the voltmeter, measure the voltages across the remaining resistors and place these values in the chart.

G) Using the voltages in your chart, confirm Kirchhoff's Loop Law. Show your work.

H) Calculate the resistance of each resistor R_1 , R_2 , and R_3 using the data you have taken. Place these values in the chart. [Do not use the color band values to find the resistance of R_1 , R_2 , and R_3 .]

I) Earlier you used Ohm's Law to calculate the total resistance of the circuit. Now you will calculate the same thing but you will use the individual resistances and the series/parallel equivalence equations. Calculate R_{tot} for this circuit.

J) Compare total resistance values you calculated from parts **E)** and **I)** by calculating a percent difference. If your percent difference is over 5% then you made a mistake somewhere. It is up to you to go back to find and correct the mistake.

Part 2 – Middle Circuit Now you are going to analyze the next circuit down on the circuit board. You can leave the leads from the power supply plugged into the board where they are, still set at +10 V. You can ignore the circuit you just dealt with as well as the circuit on the bottom of the board, it will not affect the results for this part of the lab. Again, all of the resistors with a “G” in the subscript are GIVEN values. You can find these values in **Figure 7**. The last three resistors are unknown.

A) Make another chart like the one you made before, but include all of the resistors that are in **Figure 7**. Place all four of your R_G values in your chart as well as the voltage of the power supply.

Given Values

$$R_G = 1,000 \, \Omega$$

$$R_{G1} = 10,000 \, \Omega$$

$$R_{G2} = 10,000 \, \Omega$$

$$R_{G3} = 10,000 \, \Omega$$

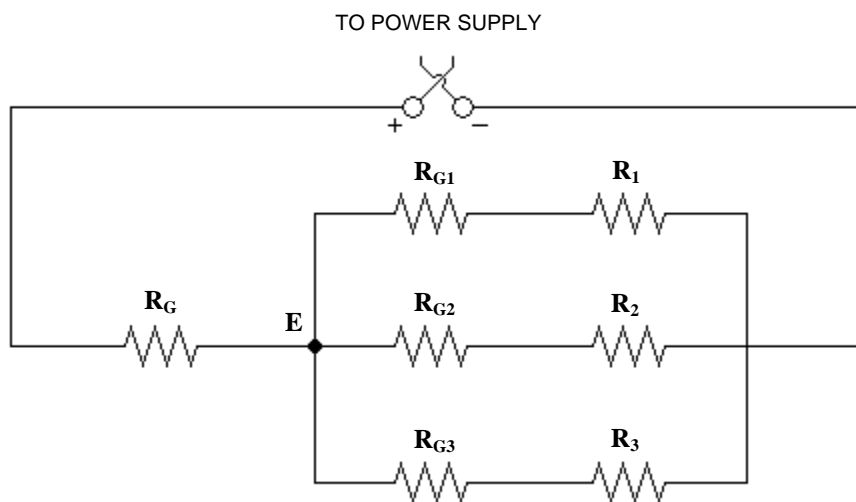

FIGURE 7 - Middle circuit diagram

B) Using the voltmeter, measure the voltage across all of the resistors in your circuit and place these values in the VIR chart.

C) Confirm the Loop Law by doing three voltage loops using different paths. Show your work.

D) Calculate the currents through all *four* of the R_G type resistors. Place these values in the chart as well as the value for the current coming out of the battery.

E) Using Ohm's Law, calculate the total resistance of the circuit and place it in the chart.

F) Using the currents you calculated for the R_G type resistors, confirm the Branch Law at point E (in **Figure 7**). Show your work.

G) Find the currents through the remaining resistors and place these values in the chart.

Question 3 Do you need to calculate these current values? Explain why or why not?

H) Using the data and calculations so far, calculate the resistances of the three unknown resistors. Place these values in the chart.

I) Using the separate resistance values and the series/parallel equivalence equations, calculate R_{tot} for the circuit.

J) Compare the total resistance values that you calculated from parts **E)** and **I)** by calculating a percent difference. If your percent difference is over 5% then you made a mistake somewhere. It is up to you to go back to find and correct the mistake.

Given Values

$$R_G = 1,000 \Omega$$

$$R_{G1} = 10,000 \Omega$$

$$R_{G2} = 10,000 \Omega$$

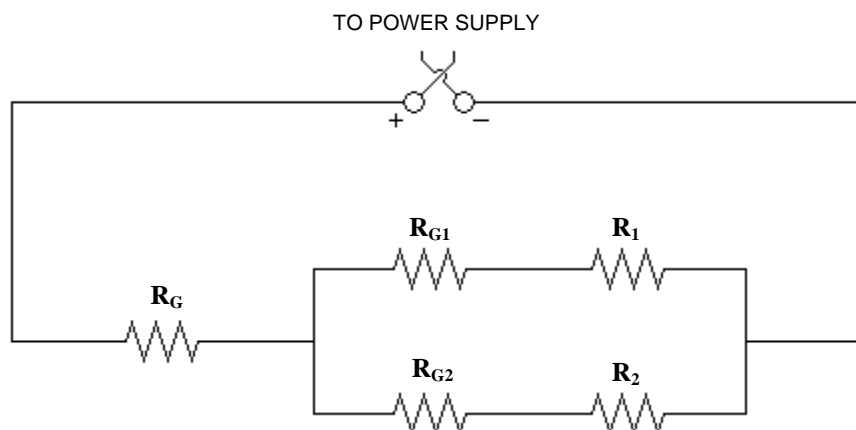

FIGURE 8 - Bottom circuit diagram

Part 3 – Bottom Circuit There is one more circuit on the circuit board. The power supply voltage is still set to +10 V. The way you analyze this circuit will be a little different than before. For this circuit you will be using Kirchhoff's Laws to determine unknown values rather than just using them as a check like before. *Make sure to follow the directions below as they are not that same as what you did before.*

- A)** Make another chart. Include all of the resistors that are in your circuit diagram. Place all the known values in your chart.
- B)** Use the voltmeter to measure the voltage across R_G and R_{G1} . Place these values in the chart.
- C)** Use the Loop Law to calculate the voltage across R_1 . Place this value in the chart.
- D)** Use the voltmeter to measure the voltage across R_1 and compare it to the one you just calculated by using a percent difference.
- E)** Calculate or determine the currents for the resistors R_G , R_{G1} , and R_1 . Place these values in the chart.
- F)** Use the Branch Law to calculate the current through R_{G2} . Place this value in the chart.
- G)** Use the voltmeter to measure the voltage across R_{G2} . Place this value in the chart.
- H)** Calculate the current through R_{G2} and compare this value to the one you calculated in **F)** by using a percent difference.
- I)** Fill out the rest of the chart with whatever methods you like, just show your work.

Part 4 – The Whole Shebang Using the series and parallel resistor equations, calculate R_{tot} for the entire circuit board. When you are finished with that calculation, turn off the power supply and disconnect it from the circuit board. Turn the dial on the voltmeter so that it is in the “ Ω range”. This will turn the voltmeter into an ohmmeter. Use it to measure the total resistance of the entire circuit board. Compare this value to the value you just calculated by doing a percent difference.

What You Need To Turn In:

Make sure that your calculations and answers are given in the section where they were asked. Show one VIR chart for each part. Make sure you show one sample calculation for each value you were asked to calculate.